



An Oshkosh Corporation Company

---

# ***Operation and Safety Manual***

*Original Instructions - Keep this manual with the machine at all times.*

***Boom Lift Models***

***800S***

***860SJ***

***S/N 0300182743 to Present***

---

**ANSI**



**3121630**

*March 20, 2014*

**NOTE:** *This manual also applies to machines with the following Serial Numbers: 0300174290, 0300180894, and 0300181347.*

## **FOREWORD**

This manual is a very important tool! Keep it with the machine at all times.

The purpose of this manual is to provide owners, users, operators, lessors, and lessees with the precautions and operating procedures essential for the safe and proper machine operation for its intended purpose.

Due to continuous product improvements, JLG Industries, Inc. reserves the right to make specification changes without prior notification. Contact JLG Industries, Inc. for updated information.

## **SAFETY ALERT SYMBOLS AND SAFETY SIGNAL WORDS**



This is the Safety Alert Symbol. It is used to alert you to the potential personal injury hazards. Obey all safety messages that follow this symbol to avoid possible injury or death

### **⚠ DANGER**

INDICATES AN IMMINENTLY HAZARDOUS SITUATION. IF NOT AVOIDED, WILL RESULT IN SERIOUS INJURY OR DEATH. THIS DECAL WILL HAVE A RED BACKGROUND.

### **⚠ WARNING**

INDICATES A POTENTIALLY HAZARDOUS SITUATION. IF NOT AVOIDED, COULD RESULT IN SERIOUS INJURY OR DEATH. THIS DECAL WILL HAVE AN ORANGE BACKGROUND.

### **⚠ CAUTION**

INDICATES A POTENTIALLY HAZARDOUS SITUATION. IF NOT AVOIDED, MAY RESULT IN MINOR OR MODERATE INJURY. IT MAY ALSO ALERT AGAINST UNSAFE PRACTICES. THIS DECAL WILL HAVE A YELLOW BACKGROUND.

### **NOTICE**

INDICATES INFORMATION OR A COMPANY POLICY THAT RELATES DIRECTLY OR INDIRECTLY TO THE SAFETY OF PERSONNEL OR PROTECTION OF PROPERTY.

**⚠ WARNING**

**THIS PRODUCT MUST COMPLY WITH ALL SAFETY RELATED BULLETINS. CONTACT JLG INDUSTRIES, INC. OR THE LOCAL AUTHORIZED JLG REPRESENTATIVE FOR INFORMATION REGARDING SAFETY-RELATED BULLETINS WHICH MAY HAVE BEEN ISSUED FOR THIS PRODUCT.**

**NOTICE**

**JLG INDUSTRIES, INC. SENDS SAFETY RELATED BULLETINS TO THE OWNER OF RECORD OF THIS MACHINE. CONTACT JLG INDUSTRIES, INC. TO ENSURE THAT THE CURRENT OWNER RECORDS ARE UPDATED AND ACCURATE.**

**NOTICE**

**JLG INDUSTRIES, INC. MUST BE NOTIFIED IMMEDIATELY IN ALL INSTANCES WHERE JLG PRODUCTS HAVE BEEN INVOLVED IN AN ACCIDENT INVOLVING BODILY INJURY OR DEATH OF PERSONNEL OR WHEN SUBSTANTIAL DAMAGE HAS OCCURRED TO PERSONAL PROPERTY OR THE JLG PRODUCT.**

**For:**

- Accident Reporting
- Product Safety Publications
- Current Owner Updates
- Questions Regarding Product Safety
- Standards and Regulations Compliance Information
- Questions Regarding Special Product Applications
- Questions Regarding Product Modifications

**Contact:**

Product Safety and Reliability Department  
JLG Industries, Inc.  
13224 Fountainhead Plaza  
Hagerstown, MD 21742  
USA

or Your Local JLG Office  
(See addresses on inside of manual cover)

**In USA:**

Toll Free: 877-JLG-SAFE (877-554-7233)

**Outside USA:**

Phone: 240-420-2661  
Fax: 301-745-3713  
E-mail: ProductSafety@JLG.com

## **REVISION LOG**

Original Issue

- March 20, 2014

<b>SECTION - PARAGRAPH, SUBJECT</b>	<b>PAGE</b>
<b>SECTION - 1 - SAFETY PRECAUTIONS</b>	
1.1 GENERAL .....	1-1
1.2 PRE-OPERATION .....	1-1
Operator Training and Knowledge .....	1-1
Workplace Inspection .....	1-2
Machine Inspection .....	1-3
1.3 OPERATION .....	1-3
General .....	1-3
Trip and Fall Hazards .....	1-4
Electrocution Hazards .....	1-5
Tipping Hazards .....	1-7
Crushing and Collision Hazards .....	1-10
1.4 TOWING, LIFTING, AND HAULING .....	1-11
1.5 MAINTENANCE .....	1-11
Maintenance Hazards .....	1-11
Battery Hazards .....	1-13
<b>SECTION - 2 - USER RESPONSIBILITIES, MACHINE PREPARATION, AND INSPECTION</b>	
2.1 PERSONNEL TRAINING .....	2-1
Operator Training .....	2-1
Training Supervision .....	2-1
Operator Responsibility .....	2-1
2.2 PREPARATION, INSPECTION, AND MAINTENANCE .....	2-2
Pre-Start Inspection .....	2-4

<b>SECTION - PARAGRAPH, SUBJECT</b>	<b>PAGE</b>
Function Check .....	2-5
General .....	2-9
2.3 HORIZONTAL AND CAPACITY LIMIT SWITCHES .....	2-10
2.4 OSCILLATING AXLE LOCKOUT TEST (IF EQUIPPED) .....	2-14
<b>SECTION - 3 - MACHINE CONTROLS AND INDICATORS</b>	
3.1 GENERAL .....	3-1
3.2 CONTROLS AND INDICATORS .....	3-1
Ground Control Console .....	3-2
Ground Control Indicator Panel .....	3-8
Platform Console .....	3-10
Platform Control Indicator Panel .....	3-16
<b>SECTION - 4 - 3MACHINE OPERATION</b>	
4.1 DESCRIPTION .....	4-1
4.2 OPERATING CHARACTERISTICS AND LIMITATIONS .....	4-1
Capacities .....	4-1
Stability .....	4-1
4.3 ENGINE OPERATION .....	4-2
Starting Procedure .....	4-2
Shutdown Procedure .....	4-3
Fuel Reserve / Shut-Off System .....	4-3
4.4 TRAVELING (DRIVING) .....	4-6
Traveling Forward and Reverse .....	4-7





<b>SECTION - PARAGRAPH, SUBJECT</b>	<b>PAGE</b>
6.7 PROPANE FUEL SYSTEM PRESSURE RELIEF .....	6-30
6.8 SUPPLEMENTAL INFORMATION .....	6-31

**SECTION - 7 - INSPECTION AND REPAIR LOG**

**LIST OF FIGURES**

2-1. Basic Nomenclature - Sheet 1 of 2 .....	2-6
2-2. Basic Nomenclature - Sheet 2 of 2 .....	2-7
2-3. Daily Walk-Around Inspection - Sheet 1 of 2 .....	2-8
2-4. Daily Walk-Around Inspection - Sheet 2 of 2 .....	2-9
2-5. Horizontal and Capacity Limit Switches - Sheet 1 of 2	2-10
2-6. Horizontal and Capacity Limit Switches - Sheet 2 of 2	2-11
2-7. Limiting and Cut-Out Switches - Sheet 1 of 2 .....	2-12
2-8. Limiting and Cut-Out Switches - Sheet 2 of 2 .....	2-13
3-1. Ground Control Console - 800S .....	3-3
3-1. Ground Control Console - 860SJ .....	3-4
3-2. Ground Control Indicator Panel .....	3-9
3-3. Platform Console .....	3-12
3-4. Platform Control Indicator Panel .....	3-18
3-5. Fuel Level Indicator .....	3-19
4-1. Position of Least Backward Stability .....	4-4
4-2. Position of Least Forward Stability .....	4-5
4-3. Grade and Side Slopes .....	4-8
4-4. Drive Disconnect Hub .....	4-11
4-5. Typical 800S/860SJ Transport .....	4-16
4-6. Lifting and Tie Down Chart .....	4-17

<b>SECTION - PARAGRAPH, SUBJECT</b>	<b>PAGE</b>
4-7. Decal Location - Sheet 1 of 5 .....	4-18
4-8. Decal Location - Sheet 2 of 5 .....	4-19
4-9. Decal Location - Sheet 3 of 5 .....	4-20
4-10. Decal Location - Sheet 4 of 5 .....	4-21
4-11. Decal Location - Sheet 5 of 5 .....	4-22
6-1. Serial Number Locations .....	6-10
6-2. Engine Operating Temperature Specifications - Deutz - Sheet 1 of 2 .....	6-11
6-3. Engine Operating Temperature Specifications - Deutz - Sheet 2 of 2 .....	6-12
6-4. Engine Operating Temperature Specifications - GM - Sheet 1 of 2 .....	6-13
6-5. Engine Operating Temperature Specifications - GM - Sheet 2 of 2 .....	6-14
6-6. Maintenance and Lubrication Diagram .....	6-15
6-7. Deutz 2011 Engine Dipstick .....	6-21
6-8. Filter Lock Assembly .....	6-30

## TABLE OF CONTENTS

---

SECTION - PARAGRAPH, SUBJECT	PAGE	SECTION - PARAGRAPH, SUBJECT	PAGE
<b>LIST OF TABLES</b>			
1-1	Minimum Approach Distances (M.A.D.) .....	1-6	
1-2	Beaufort Scale (For Reference Only) .....	1-9	
2-1	Inspection and Maintenance Table .....	2-3	
4-1	Decal Location Legend, 800S .....	4-23	
4-2	Decal Location Legend, 860SJ .....	4-27	
6-1	Operating Specifications .....	6-1	
6-2	Specifications and Performance Data .....	6-2	
6-3	Capacities .....	6-3	
6-4	Deutz D2011L04 Specifications .....	6-4	
6-5	Deutz TD 2.9 Specifications .....	6-4	
6-6	GM 3.0L .....	6-5	
6-7	Battery Specifications .....	6-5	
6-8	Tire Specifications .....	6-6	
6-9	Component Weights .....	6-6	
6-10	Hydraulic Oil .....	6-7	
6-11	Mobilfluid 424 Specs .....	6-7	
6-12	UCon Hydrolube HP-5046 .....	6-8	
6-13	Mobil DTE 13M Specs .....	6-8	
6-14	Mobil EAL 224H Specs .....	6-9	
6-15	Exxon Unisvis HVI 26 Specs .....	6-9	
6-16	Lubrication Specifications .....	6-16	
6-17	Wheel Torque Chart .....	6-28	
7-1	Inspection and Repair Log .....	7-1	

## SECTION 1. SAFETY PRECAUTIONS

### 1.1 GENERAL

This section outlines the necessary precautions for proper and safe machine usage and maintenance. It is mandatory that a daily routine is established based on the content of this manual to promote proper machine usage. A maintenance program, using the information provided in this manual and the Service and Maintenance Manual, must also be established by a qualified person and must be followed to ensure that the machine is safe to operate.

The owner/user/operator/lessor/lessee of the machine must not accept operating responsibility until this manual has been read, training is accomplished, and operation of the machine has been completed under the supervision of an experienced and qualified operator.

This section contains the responsibilities of the owner, user, operator, lessor, and lessee concerning safety, training, inspection, maintenance, application, and operation. If there are any questions with regard to safety, training, inspection, maintenance, application, and operation, please contact JLG Industries, Inc. ("JLG").

### WARNING

**FAILURE TO COMPLY WITH THE SAFETY PRECAUTIONS LISTED IN THIS MANUAL COULD RESULT IN MACHINE DAMAGE, PROPERTY DAMAGE, PERSONAL INJURY OR DEATH.**

### 1.2 PRE-OPERATION

#### Operator Training and Knowledge

- The Operation and Safety Manual must be read and understood in its entirety before operating the machine. For clarification, questions, or additional information regarding any portions of this manual, contact JLG Industries, Inc.

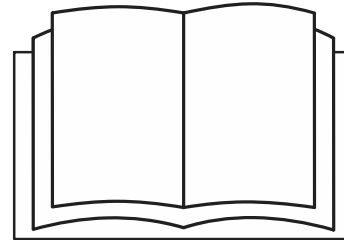

## **SECTION 1 - SAFETY PRECAUTIONS**

---

- An operator must not accept operating responsibilities until adequate training has been given by competent and authorized persons.
- Allow only those authorized and qualified personnel to operate the machine who have demonstrated that they understand the safe and proper operation and maintenance of the unit.
- Read, understand, and obey all DANGERS, WARNINGS, CAUTIONS, and operating instructions on the machine and in this manual.
- Ensure that the machine is to be used in a manner which is within the scope of its intended application as determined by JLG.
- All operating personnel must be familiar with the emergency controls and emergency operation of the machine as specified in this manual.
- Read, understand, and obey all applicable employer, local, and governmental regulations as they pertain to your utilization and application of the machine.

### **Workplace Inspection**

- Precautions to avoid all hazards in the work area must be taken by the user before and during operation of the machine.
- Do not operate or raise the platform from a position on trucks, trailers, railway cars, floating vessels, scaffolds or other equipment unless the application is approved in writing by JLG.
- Before operation, check work area for overhead hazards such as electric lines, bridge cranes, and other potential overhead obstructions.
- Check operating surfaces for holes, bumps, drop-offs, obstructions, debris, concealed holes, and other potential hazards.
- Check the work area for hazardous locations. Do not operate the machine in hazardous environments unless approved for that purpose by JLG.
- Ensure that the ground conditions are adequate to support the maximum tire load indicated on the tire load decals located on the chassis adjacent to each wheel. Do not travel on unsupported surfaces.

### Machine Inspection

- Do not operate this machine until the inspections and functional checks as specified in Section 2 of this manual have been performed.
- Do not operate this machine until it has been serviced and maintained according to the maintenance and inspection requirements as specified in the machine's Service and Maintenance Manual.
- Ensure all safety devices are operating properly. Modification of these devices is a safety violation.

### **WARNING**

**MODIFICATION OR ALTERATION OF AN AERIAL WORK PLATFORM SHALL BE MADE ONLY WITH PRIOR WRITTEN PERMISSION FROM THE MANUFACTURER.**

- Do not operate any machine on which the safety or instruction placards or decals are missing or illegible.
- Check the machine for modifications to original components. Ensure that any modifications have been approved by JLG.
- Avoid accumulation of debris on platform floor. Keep mud, oil, grease, and other slippery substances from footwear and platform floor.

### 1.3 OPERATION

#### General

- Machine operation requires your full attention. Bring the machine to a full stop before using any device, i.e. cell phones, two-way radios, etc. that will distract your attention from safely operating the machine.
- Do not use the machine for any purpose other than positioning personnel, their tools, and equipment.
- Before operation, the user must be familiar with the machine capabilities and operating characteristics of all functions.
- Never operate a malfunctioning machine. If a malfunction occurs, shut down the machine. Remove the unit from service and notify the proper authorities.
- Do not remove, modify, or disable any safety devices.
- Never slam a control switch or lever through neutral to an opposite direction. Always return switch to neutral and stop before moving the switch to the next function. Operate controls with slow and even pressure.
- Do not allow personnel to tamper with or operate the machine from the ground with personnel in the platform, except in an emergency.

## SECTION 1 - SAFETY PRECAUTIONS

---

- Do not carry materials directly on platform railing unless approved by JLG.
- When two or more persons are in the platform, the operator shall be responsible for all machine operations.
- Always ensure that power tools are properly stowed and never left hanging by their cord from the platform work area.
- When driving, always position boom over rear axle in line with the direction of travel. Remember, if boom is over the front axle, steer and drive functions will be reversed.
- Do not assist a stuck or disabled machine by pushing or pulling except by pulling at the chassis tie-down lugs.
- Fully lower platform and shut off all power before leaving machine.
- Remove all rings, watches, and jewelry when operating machine. Do not wear loose fitting clothing or long hair unrestrained which may become caught or entangled in equipment.
- Persons under the influence of drugs or alcohol or who are subject to seizures, dizziness or loss of physical control must not operate this machine.

### Trip and Fall Hazards

- During operation, occupants in the platform must wear a full body harness with a lanyard attached to an authorized lanyard anchorage point. Attach only one (1) lanyard per lanyard anchorage point..

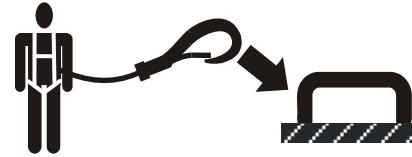

- Enter and exit only through gate area. Use extreme caution when entering or leaving platform. Ensure that the platform assembly is fully lowered. Face the machine when entering or leaving the platform. Always maintain “three point contact” with the machine, using two hands and one foot or two feet and one hand at all times during entry and exit.

- Before operating the machine, make sure all gates are closed and fastened in their proper position.

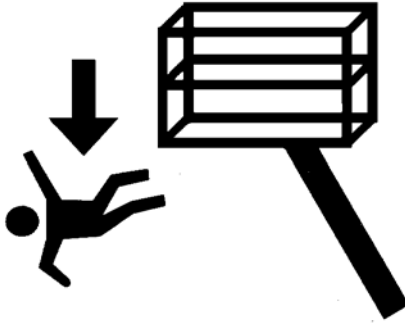

- Keep both feet firmly positioned on the platform floor at all times. Never position ladders, boxes, steps, planks, or similar items on unit to provide additional reach for any purpose.
- Keep oil, mud, and slippery substances cleaned from footwear and the platform floor.

**Electrocution Hazards**

- This machine is not insulated and does not provide protection from contact or proximity to electrical current.

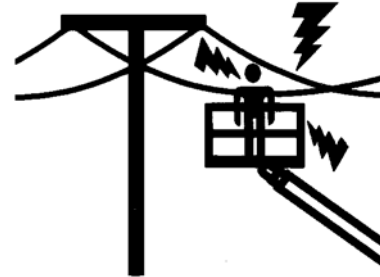

## SECTION 1 - SAFETY PRECAUTIONS

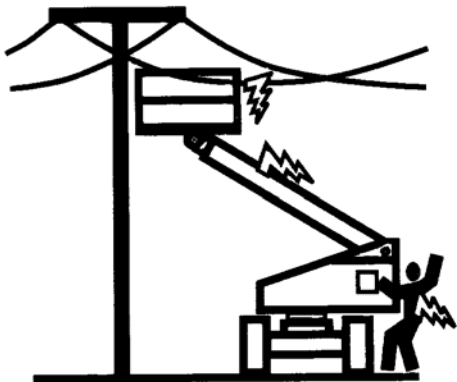

- Maintain distance from electrical lines, apparatus, or any energized (exposed or insulated) parts according to the Minimum Approach Distance (MAD) as shown in Table 1-1.
- Allow for machine movement and electrical line swaying.

**Table 1-1. Minimum Approach Distances (M.A.D.)**

<b>Voltage Range (Phase to Phase)</b>	<b>MINIMUM APPROACH DISTANCE in Feet (Meters)</b>
0 to 50 KV	10 (3)
Over 50KV to 200 KV	15 (5)
Over 200 KV to 350 KV	20 (6)
Over 350 KV to 500 KV	25 (8)
Over 500 KV to 750 KV	35 (11)
Over 750 KV to 1000 KV	45 (14)

**NOTE:** *This requirement shall apply except where employer, local or governmental regulations are more stringent.*

- Maintain a clearance of at least 10 ft. (3m) between any part of the machine and its occupants, their tools, and their equipment from any electrical line or apparatus carrying up to 50,000 volts. One foot additional clearance is required for every additional 30,000 volts or less.



- The minimum approach distance may be reduced if insulating barriers are installed to prevent contact, and the barriers are rated for the voltage of the line being guarded. These barriers shall not be part of (or attached to) the machine. The minimum approach distance shall be reduced to a distance within the designed working dimensions of the insulating barrier. This determination shall be made by a qualified person in accordance with the employer, local, or governmental requirements for work practices near energized equipment

**⚠ DANGER**

**DO NOT MANEUVER MACHINE OR PERSONNEL INSIDE PROHIBITED ZONE (MAD). ASSUME ALL ELECTRICAL PARTS AND WIRING ARE ENERGIZED UNLESS KNOWN OTHERWISE.**

**Tipping Hazards**

- The user must be familiar with the surface before driving. Do not exceed the allowable sideslope and grade while driving.

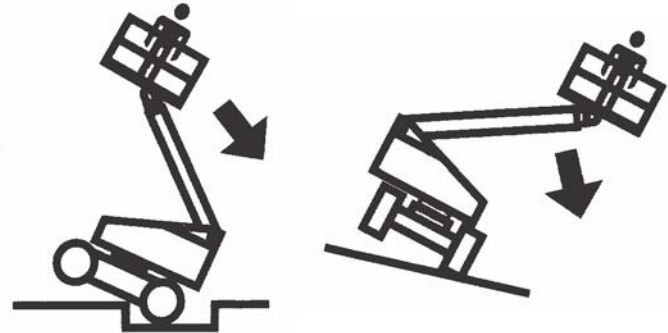

- Do not elevate platform or drive with platform elevated while on or near a sloping, uneven, or soft surface. Ensure machine is positioned on a firm, level and smooth surface before elevating platform or driving with the platform in the elevated position.
- Before driving on floors, bridges, trucks, and other surfaces, check allowable capacity of the surfaces.

## **SECTION 1 - SAFETY PRECAUTIONS**

---

- Never exceed the maximum work load as specified on the platform. Keep all loads within the confines of the platform, unless authorized by JLG.
- Keep the chassis of the machine a minimum of 2 ft. (0.6m) from holes, bumps, drop-offs, obstructions, debris, concealed holes, and other potential hazards at the ground level.
- Do not push or pull any object with the boom.
- Never attempt to use the machine as a crane. Do not tie-off machine to any adjacent structure. Never attach wire, cable, or any similar items to platform.
- Do not operate the machine when wind conditions exceed 28 mph (12.5 m/s). Refer to Table 1-2, Beaufort Scale (For Reference Only).
- Do not increase the surface area of the platform or the load. Increase of the area exposed to the wind will decrease stability.
- Do not increase the platform size with unauthorized deck extensions or attachments.
- If boom assembly or platform is in a position that one or more wheels are off the ground, all persons must be removed before attempting to stabilize the machine. Use cranes, forklift trucks, or other appropriate equipment to stabilize machine.

**NOTICE**

DO NOT OPERATE THE MACHINE WHEN WIND CONDITIONS EXCEED 28 MPH (12.5 M/S).

**Table 1-2. Beaufort Scale (For Reference Only)**

Beaufort Number	Wind Speed		Description	Land Conditions
	mph	m/s		
0	0	0-0.2	Calm	Calm. Smoke rises vertically
1	1-3	0.3-1.5	Light air	Wind motion visible in smoke
2	4-7	1.6-3.3	Light breeze	Wind felt on exposed skin. Leaves rustle
3	8-12	3.4-5.4	Gentle breeze	Leaves and smaller twigs in constant motion
4	13-18	5.5-7.9	Moderate breeze	Dust and loose paper raised. Small branches begin to move.
5	19-24	8.0-10.7	Fresh breeze	Smaller trees sway.
6	25-31	10.8-13.8	Strong breeze	Large branches in motion. Flags waving near horizontal. Umbrella use becomes difficult.
7	32-38	13.9-17.1	Near Gale/Moderate Gale	Whole trees in motion. Effort needed to walk against the wind.
8	39-46	17.2-20.7	Fresh Gale	Twigs broken from trees. Cars veer on road.
9	47-54	20.8-24.4	Strong Gale	Light structure damage.

### Crushing and Collision Hazards

- Approved head gear must be worn by all operating and ground personnel.
- Check work area for clearances overhead, on sides, and bottom of platform when lifting or lowering platform, and driving.

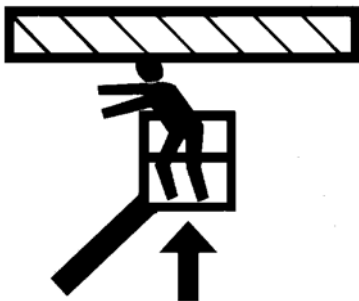

- During operation, keep all body parts inside platform railing.
- Use the boom functions, not the drive function, to position the platform close to obstacles.
- Always post a lookout when driving in areas where vision is obstructed.

- Keep non-operating personnel at least 6 ft. (1.8m) away from machine during all driving and swing operations.
- Under all travel conditions, the operator must limit travel speed according to conditions of ground surface, congestion, visibility, slope, location of personnel, and other factors which may cause collision or injury to personnel.
- Be aware of stopping distances in all drive speeds. When driving in high speed, switch to low speed before stopping. Travel grades in low speed only.
- Do not use high speed drive in restricted or close quarters or when driving in reverse.
- Exercise extreme caution at all times to prevent obstacles from striking or interfering with operating controls and persons in the platform.
- Be sure that operators of other overhead and floor level machines are aware of the aerial work platform's presence. Disconnect power to overhead cranes.
- Warn personnel not to work, stand, or walk under a raised boom or platform. Position barricades on floor if necessary.

### 1.4 TOWING, LIFTING, AND HAULING

- Never allow personnel in platform while towing, lifting, or hauling.
- This machine should not be towed, except in the event of emergency, malfunction, power failure, or loading/unloading. Refer to the Emergency Procedures section of this manual for emergency towing procedures.
- Ensure boom is in the stowed position and the turntable locked prior to towing, lifting or hauling. The platform must be completely empty of tools.
- When lifting machine, lift only at designated areas of the machine. Lift the unit with equipment of adequate capacity.
- Refer to the Machine Operation section of this manual for lifting information.

### 1.5 MAINTENANCE

This sub-section contains general safety precautions which must be observed during maintenance of this machine. Additional precautions to be observed during machine maintenance are inserted at the appropriate points in this manual and in the Service and Maintenance Manual. It is of utmost importance that maintenance personnel pay strict attention to these precautions to avoid possible injury to personnel or damage to the machine or property. A maintenance program must be established by a qualified person and must be followed to ensure that the machine is safe.

#### Maintenance Hazards

- Shut off power to all controls and ensure that all moving parts are secured from inadvertent motion prior to performing any adjustments or repairs.
- Never work under an elevated platform until it has been fully lowered to the full down position, if possible, or otherwise supported and restrained from movement with appropriate safety props, blocking, or overhead supports.
- DO NOT attempt to repair or tighten any hydraulic hoses or fittings while the machine is powered on or when the hydraulic system is under pressure.
- Always relieve hydraulic pressure from all hydraulic circuits before loosening or removing hydraulic components.

## SECTION 1 - SAFETY PRECAUTIONS

---

- DO NOT use your hand to check for leaks. Use a piece of cardboard or paper to search for leaks. Wear gloves to help protect hands from spraying fluid.



- Ensure replacement parts or components are identical or equivalent to original parts or components.
- Never attempt to move heavy parts without the aid of a mechanical device. Do not allow heavy objects to rest in an unstable position. Ensure adequate support is provided when raising components of the machine.

- Do not use machine as a ground for welding.
- When performing welding or metal cutting operations, precautions must be taken to protect the chassis from direct exposure to weld and metal cutting spatter.
- Do not refuel the machine with the engine running.
- Use only approved non-flammable cleaning solvents.
- Do not replace items critical to stability, such as batteries or solid tires, with items of different weight or specification. Do not modify unit in any way to affect stability.
- Refer to the Service and Maintenance Manual for the weights of critical stability items.

### **⚠ WARNING**

**MODIFICATION OR ALTERATION OF AN AERIAL WORK PLATFORM SHALL BE MADE ONLY WITH PRIOR WRITTEN PERMISSION FROM THE MANUFACTURER.**

## **Battery Hazards**

- Always disconnect batteries when servicing electrical components or when performing welding on the machine.
- Do not allow smoking, open flame, or sparks near battery during charging or servicing.
- Do not contact tools or other metal objects across the battery terminals.
- Always wear hand, eye, and face protection when servicing batteries. Ensure that battery acid does not come in contact with skin or clothing.

### **CAUTION**

**BATTERY FLUID IS HIGHLY CORROSIVE. AVOID CONTACT WITH SKIN AND CLOTHING AT ALL TIMES. IMMEDIATELY RINSE ANY CONTACTED AREA WITH CLEAN WATER AND SEEK MEDICAL ATTENTION.**

- Charge batteries only in a well ventilated area.
- Avoid overfilling the battery fluid level. Add distilled water to batteries only after the batteries are fully charged.





## **SECTION 2. USER RESPONSIBILITIES, MACHINE PREPARATION, AND INSPECTION**

### **2.1 PERSONNEL TRAINING**

The aerial platform is a personnel handling device; so it is necessary that it be operated and maintained only by trained personnel.

Persons under the influence of drugs or alcohol or who are subject to seizures, dizziness or loss of physical control must not operate this machine.

#### **Operator Training**

Operator training must cover:

1. Use and limitations of the controls in the platform and at the ground, emergency controls and safety systems.
2. Control labels, instructions, and warnings on the machine.
3. Rules of the employer and government regulations.
4. Use of approved fall protection device.
5. Enough knowledge of the mechanical operation of the machine to recognize a malfunction or potential malfunction.

6. The safest means to operate the machine where overhead obstructions, other moving equipment, and obstacles, depressions, holes, dropoffs.
7. Means to avoid the hazards of unprotected electrical conductors.
8. Specific job requirements or machine application.

#### **Training Supervision**

Training must be done under the supervision of a qualified person in an open area free of obstructions until the trainee has developed the ability to safely control and operate the machine.

#### **Operator Responsibility**

The operator must be instructed that he/she has the responsibility and authority to shut down the machine in case of a malfunction or other unsafe condition of either the machine or the job site.

## **2.2 PREPARATION, INSPECTION, AND MAINTENANCE**

The following table covers the periodic machine inspections and maintenance required by JLG Industries, Inc. Consult local regulations for further requirements for aerial work platforms. The frequency of inspections and maintenance must be increased as necessary when the machine is used in a harsh or hostile environment, if the machine is used with increased frequency, or if the machine is used in a severe manner.

### **NOTICE**

**JLG INDUSTRIES, INC. RECOGNIZES A FACTORY-TRAINED SERVICE TECHNICIAN AS A PERSON WHO HAS SUCCESSFULLY COMPLETED THE JLG SERVICE TRAINING SCHOOL FOR THE SPECIFIC JLG PRODUCT MODEL.**

## SECTION 2 - USER RESPONSIBILITIES, MACHINE PREPARATION, AND INSPECTION

**Table 2-1. Inspection and Maintenance Table**

Type	Frequency	Primary Responsibility	Service Qualification	Reference
Pre-Start Inspection	Before using each day; or whenever there's an Operator change.	User or Operator	User or Operator	Operator and Safety Manual
Pre-Delivery Inspection (See Note)	Before each sale, lease, or rental delivery.	Owner, Dealer, or User	Qualified JLG Mechanic	Service and Maintenance Manual and applicable JLG inspection form
Frequent Inspection (See Note)	In service for 3 months or 150 hours, whichever comes first; or Out of service for a period of more than 3 months; or Purchased used.	Owner, Dealer, or User	Qualified JLG Mechanic	Service and Maintenance Manual and applicable JLG inspection form
Annual Machine Inspection (See Note)	Annually, no later than 13 months from the date of prior inspection.	Owner, Dealer, or User	Factory Trained Service Technician (Recommended)	Service and Maintenance Manual and applicable JLG inspection form
Preventative Maintenance	At intervals as specified in the Service and Maintenance Manual.	Owner, Dealer, or User	Qualified JLG Mechanic	Service and Maintenance Manual
<b>NOTE:</b> Inspection forms are available from JLG. Use the Service and Maintenance Manual to perform inspections.				

## SECTION 2 - USER RESPONSIBILITIES, MACHINE PREPARATION, AND INSPECTION

### Pre-Start Inspection

The Pre-Start Inspection should include each of the following:

1. **Cleanliness** – Check all surfaces for leakage (oil, fuel, or battery fluid) or foreign objects. Report any leakage to the proper maintenance personnel.
2. **Structure** - Inspect the machine structure for dents, damage, weld or parent metal cracks or other discrepancies.

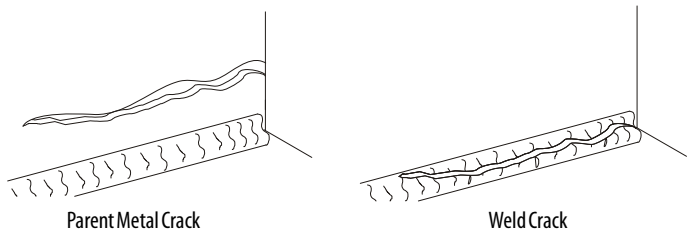

3. **Decals and Placards** – Check all for cleanliness and legibility. Make sure none of the decals and placards are missing. Make sure all illegible decals and placards are cleaned or replaced.
4. **Operators and Safety Manuals** – Make sure a copy of the Operator and Safety Manual, EMI Safety Manual (Domestic only), and ANSI Manual of Responsibilities (Domestic only) is enclosed in the weather resistant storage container.

5. **“Walk-Around” Inspection** – Refer to Figure 2-3. and Figure 2-4.
6. **Battery** – Charge as required.
7. **Fuel** (Combustion Engine Powered Machines) – Add the proper fuel as necessary.
8. **Engine Oil Supply** – Ensure the engine oil level is at the Full mark on the dipstick and the filler cap is secure.
9. **Hydraulic Oil** – Check the hydraulic oil level. Ensure hydraulic oil is added as required.
10. **Function Check** – Once the “Walk-Around” Inspection is complete, perform a functional check of all systems in an area free of overhead and ground level obstructions. Refer to Section 4 for more specific instructions.

### **⚠ WARNING**

**IF THE MACHINE DOES NOT OPERATE PROPERLY, TURN OFF THE MACHINE IMMEDIATELY! REPORT THE PROBLEM TO THE PROPER MAINTENANCE PERSONNEL. DO NOT OPERATE THE MACHINE UNTIL IT IS DECLARED SAFE FOR OPERATION.**

### Function Check

Perform the Function Check as follows:

1. From the ground control console with no load in the platform:
  - a. Check that all guards protecting the switches or locks are in place;
  - b. Operate all functions and check all limiting and cut-out switches;
  - c. Check auxiliary power (or manual descent);
  - d. Ensure that all machine functions are disabled when the Emergency Stop Button is activated.
2. From the platform control console:
  - a. Ensure that the control console is firmly secured in the proper location;
  - b. Check that all guards protecting the switches or locks are in place;
  - c. Operate all functions and check all limiting and cut-out switches;
  - d. Ensure that all machine functions are disabled when the Emergency Stop Button is pushed in.
3. With the platform in the transport (stowed) position:
  - a. Drive the machine on a grade, not to exceed the rated gradeability, and stop to ensure the brakes hold;
  - b. Check the tilt sensor alarm to ensure proper operation.

## SECTION 2 - USER RESPONSIBILITIES, MACHINE PREPARATION, AND INSPECTION

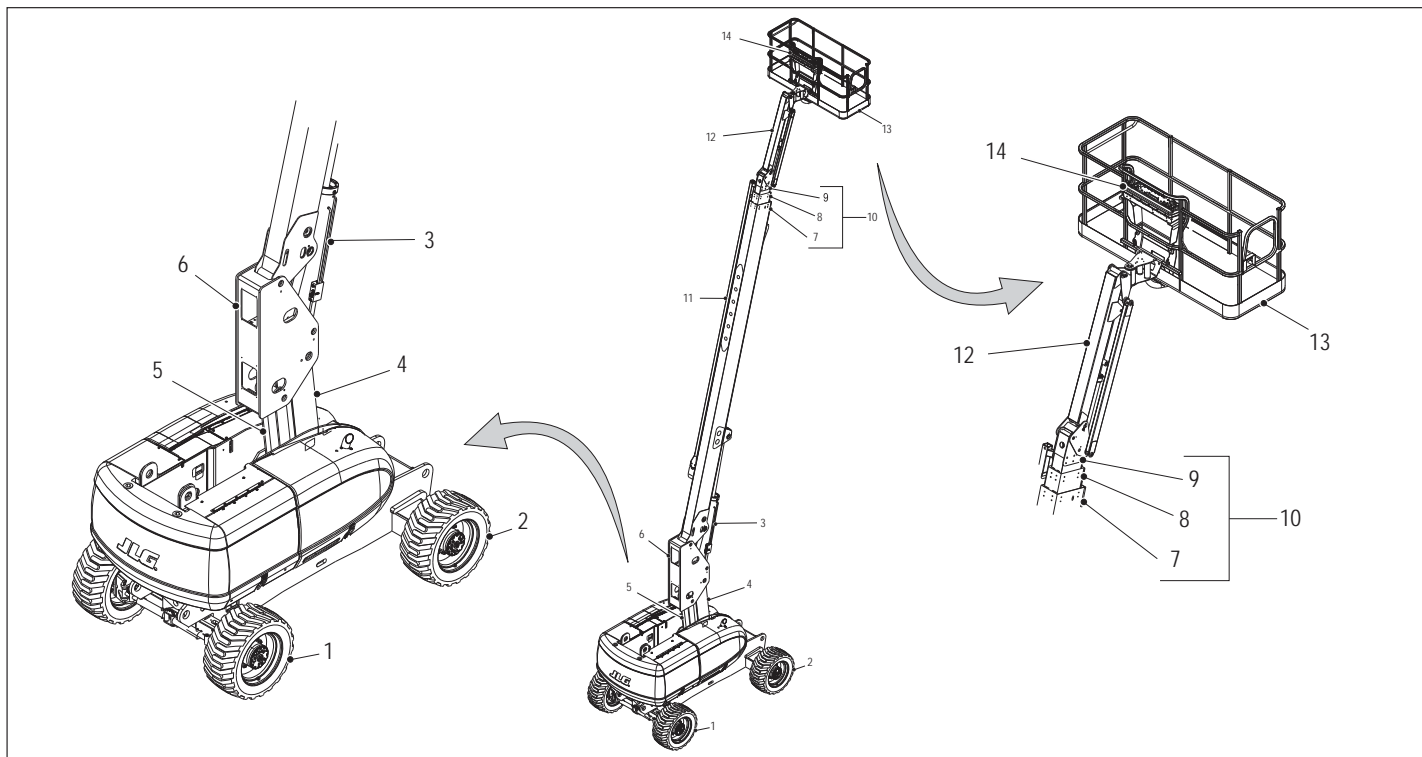

Figure 2-1. Basic Nomenclature - Sheet 1 of 2

1. Steer Wheels
2. Drive Wheels
3. Lift Cylinder
4. Tower
5. Level Link
6. Upright
7. Base Boom Section
8. Mid Boom Section
9. Fly Boom Section
10. Boom Assembly
11. Power Track
12. Jib (If Equipped)
13. Platform
14. Platform Console

**Figure 2-2. Basic Nomenclature - Sheet 2 of 2**

## SECTION 2 - USER RESPONSIBILITIES, MACHINE PREPARATION, AND INSPECTION

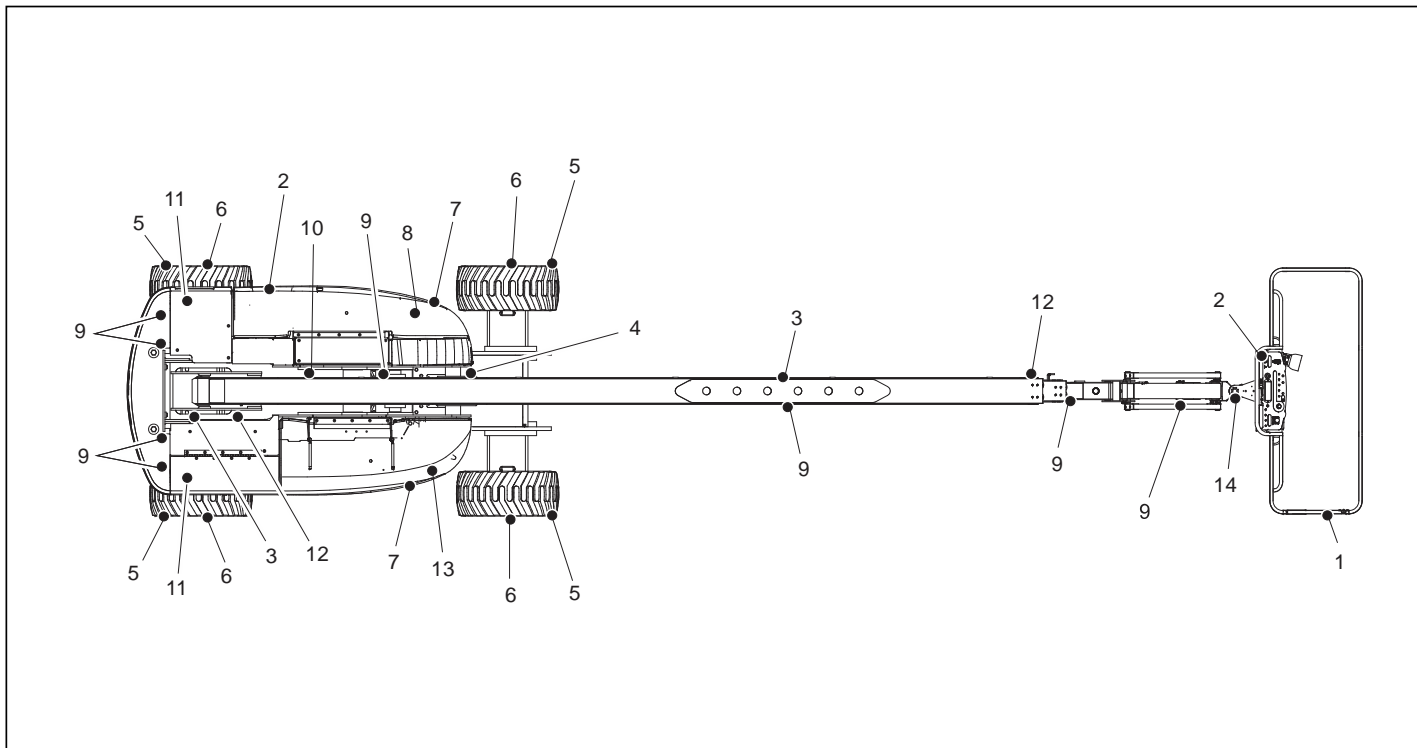

Figure 2-3. Daily Walk-Around Inspection - Sheet 1 of 2



### General

Begin the "Walk-Around Inspection" at Item 1, as noted on the diagram. Continue to the right (counterclockwise viewed from top) checking each item in sequence for the conditions listed in the following checklist.

#### **WARNING**

**TO AVOID POSSIBLE INJURY, BE SURE MACHINE POWER IS OFF.**

**DO NOT OPERATE MACHINE UNTIL ALL MALFUNCTIONS HAVE BEEN CORRECTED.**

**INSPECTION NOTE:** *On all components, make sure there are no loose or missing parts, that they are securely fastened, and no visible damage, leaks or excessive wear exists in addition to any other criteria mentioned.*

- 1. Platform Assembly and Gate** - Footswitch works properly, not modified, disabled or blocked. Latch, stop, and hinges in working condition.
- 2. Platform & Ground Control Consoles** - Switches and levers return to neutral, decals/placards secure and legible, control markings legible.
- 3. Boom Sections/Uprights/Turntable** - See Inspection Note.
- 4. Swing Drive** - No evidence of damage.

- 5. Wheel/Tire Assemblies** - No loose or missing lug nuts, proper inflation (pneumatic). Inspect for worn tread, cuts, tears or other discrepancies. Inspect wheels for damage and corrosion.
- 6. Drive Motor, Brake, and Hub** - No evidence of leakage.
- 7. Hood Assemblies** - See Inspection Note.
- 8. Auxiliary Hydraulic Pump** - See Inspection Note.
- 9. All Hydraulic Cylinders** - No visible damage; pivot pins and hydraulic hoses undamaged, not leaking.
- 10. Turntable Bearing** - Evidence of proper lubrication. No evidence of loose bolts or looseness between bearing and machine.
- 11. Tie Rod Ends and Steering Spindles** - See Inspection Note.
- 12. Horizontal and Capacity Limit Switches** - Switches operate properly.
- 13. Main Hydraulic Pump** - See Inspection Note.
- 14. Platform Rotator** - See Inspection Note.

**Figure 2-4. Daily Walk-Around Inspection - Sheet 2 of 2**

**2.3 HORIZONTAL AND CAPACITY LIMIT SWITCHES**

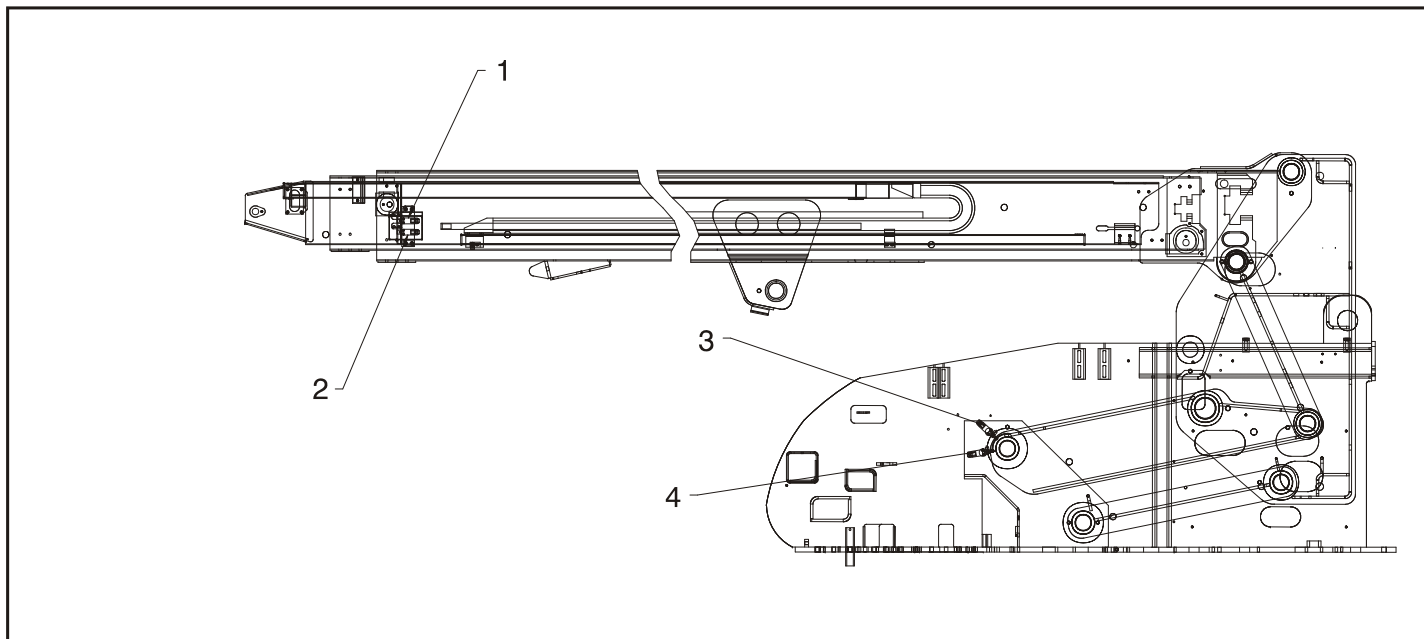

**Figure 2-5. Horizontal and Capacity Limit Switches - Sheet 1 of 2**

## SECTION 2 - USER RESPONSIBILITIES, MACHINE PREPARATION, AND INSPECTION

---

Item	Description	Operation Characteristic
1	<b>Boom Capacity Length Switch</b>	Activates platform capacity light to indicate the platform capacity at a designated boom length.
2	<b>Boom Extension Switch</b>	Reduces drive speed when boom reaches a designated length.
3	<b>Boom Capacity Angle Switch</b>	Activates platform capacity light to indicate the platform capacity at a designated boom height.
4	<b>Boom Elevation Switch</b>	Reduces drive speed when boom is raised above horizontal.

**Figure 2-6. Horizontal and Capacity Limit Switches - Sheet 2 of 2**

## SECTION 2 - USER RESPONSIBILITIES, MACHINE PREPARATION, AND INSPECTION

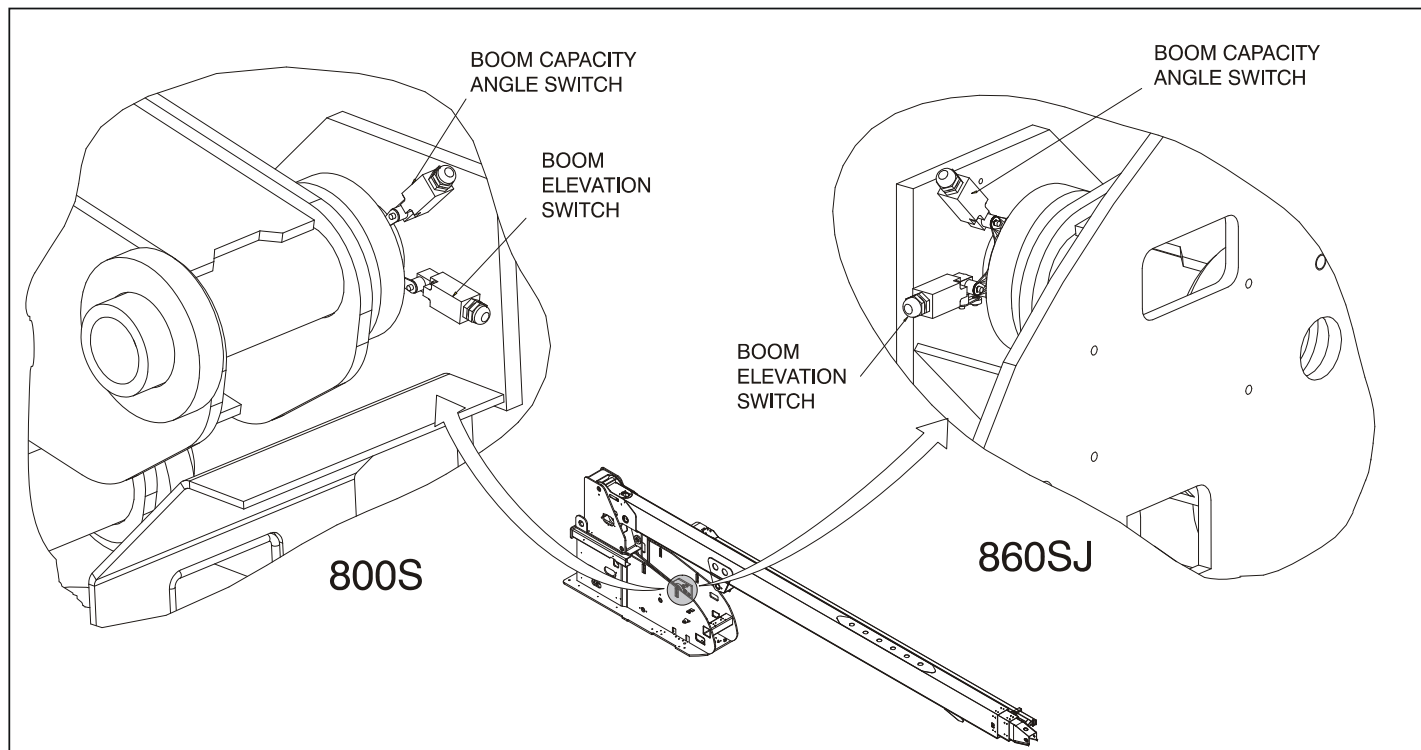
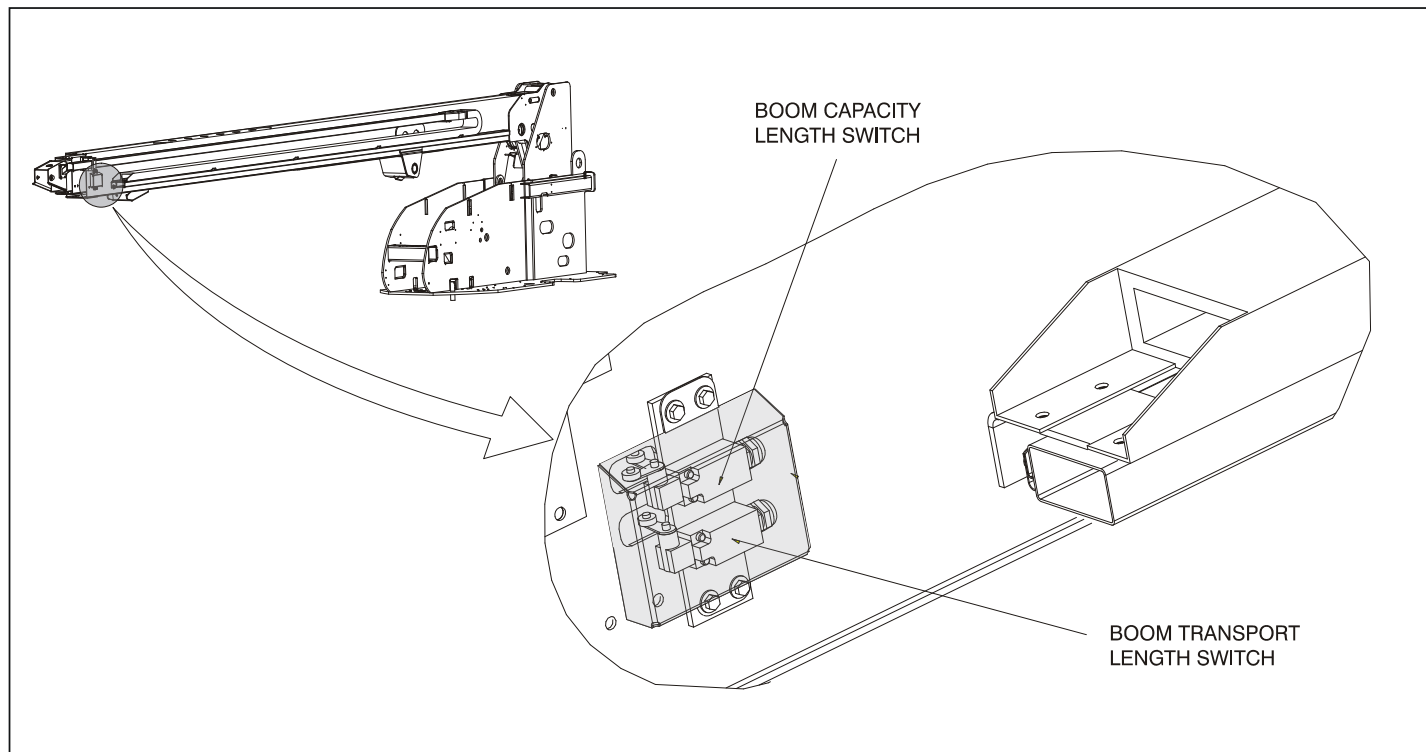

Figure 2-7. Limiting and Cut-Out Switches - Sheet 1 of 2

**SECTION 2 - USER RESPONSIBILITIES, MACHINE PREPARATION, AND INSPECTION**



**Figure 2-8. Limiting and Cut-Out Switches - Sheet 2 of 2**

### 2.4 OSCILLATING AXLE LOCKOUT TEST (IF EQUIPPED)

#### **NOTICE**

**LOCKOUT SYSTEM TEST MUST BE PERFORMED QUARTERLY, ANY TIME A SYSTEM COMPONENT IS REPLACED, OR WHEN IMPROPER SYSTEM OPERATION IS SUSPECTED.**

**NOTE:** *Ensure boom is fully retracted, lowered, and centered between drive wheels prior to beginning lockout cylinder test.*

1. Place a 6 inches (15.2 cm) high block with ascension ramp in front of left front wheel.
2. From platform control console, start engine
3. Place the Drive control lever to the forward position and carefully drive machine up ascension ramp until left front wheel is on top of block.
4. Carefully activate Swing control lever and position boom over right side of machine.
5. With boom over right side of machine, place Drive control lever to Reverse and drive machine off of block and ramp.
6. Have an assistant check to see that left front or right rear wheel remains elevated in position off of ground.
7. Carefully activate Swing control lever and return boom to stowed position (centered between drive wheels). When boom reaches center, stowed position, lockout cylinders should release and allow wheel to rest on ground, it may be necessary to activate Drive to release cylinders.

## ***SECTION 2 - USER RESPONSIBILITIES, MACHINE PREPARATION, AND INSPECTION***

---

- 8.** Place the 6 inches (15.2 cm) high block with ascension ramp in front of right front wheel.
- 9.** Place Drive control lever to Forward and carefully drive machine up ascension ramp until right front wheel is on top of block.
- 10.** With boom over left side of machine, place Drive control lever to Reverse and drive machine off of block and ramp.
- 11.** Have an assistant check to see that right front or left rear wheel remains elevated in position off of ground.
- 12.** Carefully activate Swing control lever and return boom to stowed position (centered between drive wheels). When boom reaches center, stowed position, lockout cylinders should release and allow wheel to rest on ground, it may be necessary activate Drive to release cylinders.
- 13.** If lockout cylinders do not function properly, have qualified personnel correct the malfunction prior to any further operation.





## SECTION 3. MACHINE CONTROLS AND INDICATORS

### 3.1 GENERAL

#### **NOTICE**

**THE MANUFACTURER HAS NO DIRECT CONTROL OVER MACHINE APPLICATION AND OPERATION. THE USER AND OPERATOR ARE RESPONSIBLE FOR CONFORMING WITH GOOD SAFETY PRACTICES.**

This section provides the necessary information needed to understand control functions.

### 3.2 CONTROLS AND INDICATORS

**NOTE:** All machines are equipped with control consoles that use symbols to indicate control functions. On ANSI machines refer to decal located on the control box guard in front of the control box or by the ground controls for these symbols and the corresponding functions.

**NOTE:** The indicator panels use different shaped symbols to alert the operator to different types of operational situations that could arise. The meaning of those symbols are explained below.



Indicates a potentially hazardous situation, which if not corrected, could result in serious injury or death. This indicator will be red.



Indicates an abnormal operating condition, which if not corrected, may result in machine interruption or damage. This indicator will be yellow.



Indicates important information regarding the operating condition, i.e. procedures essential for safe operation. This indicator will be green with the exception of the capacity indicator which will be green or yellow depending upon platform position.

## SECTION 3 - MACHINE CONTROLS AND INDICATORS

### **⚠ WARNING**

TO AVOID SERIOUS INJURY, DO NOT OPERATE MACHINE IF ANY CONTROL LEVERS OR TOGGLE SWITCHES CONTROLLING PLATFORM MOVEMENT DO NOT RETURN TO THE OFF POSITION WHEN RELEASED.

### Ground Control Console

(See Figure 3-1., Ground Control Console - 800S and Figure 3-1., Ground Control Console - 860SJ).

**NOTE:** When Power/Emergency Stop switch is in the "ON" position and engine is not running, an alarm will sound, indicating Ignition is "ON".

### **⚠ CAUTION**

WHEN THE MACHINE IS SHUT DOWN THE MASTER/EMERGENCY STOP SWITCH MUST BE POSITIONED TO THE "OFF" POSITION TO PREVENT DRAINING THE BATTERY.

**NOTE:** The Function Enable switch must be held down in order to operate Telescope, Swing, Lift, Jib Lift, Platform Level Override, and Platform Rotate functions.



#### 1. Indicator Panel.

The LED Indicator Panel contains indicator lights that signal problem conditions or functions operating during machine operation.

### **⚠ WARNING**

TO AVOID SERIOUS INJURY, DO NOT OPERATE MACHINE IF ANY CONTROL LEVERS OR TOGGLE SWITCHES CONTROLLING PLATFORM MOVEMENT DO NOT RETURN TO THE OFF POSITION WHEN RELEASED.

#### 2. Telescope Control

Provides extension and retraction of the boom.

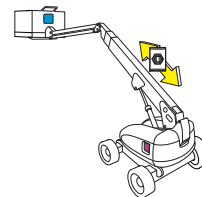

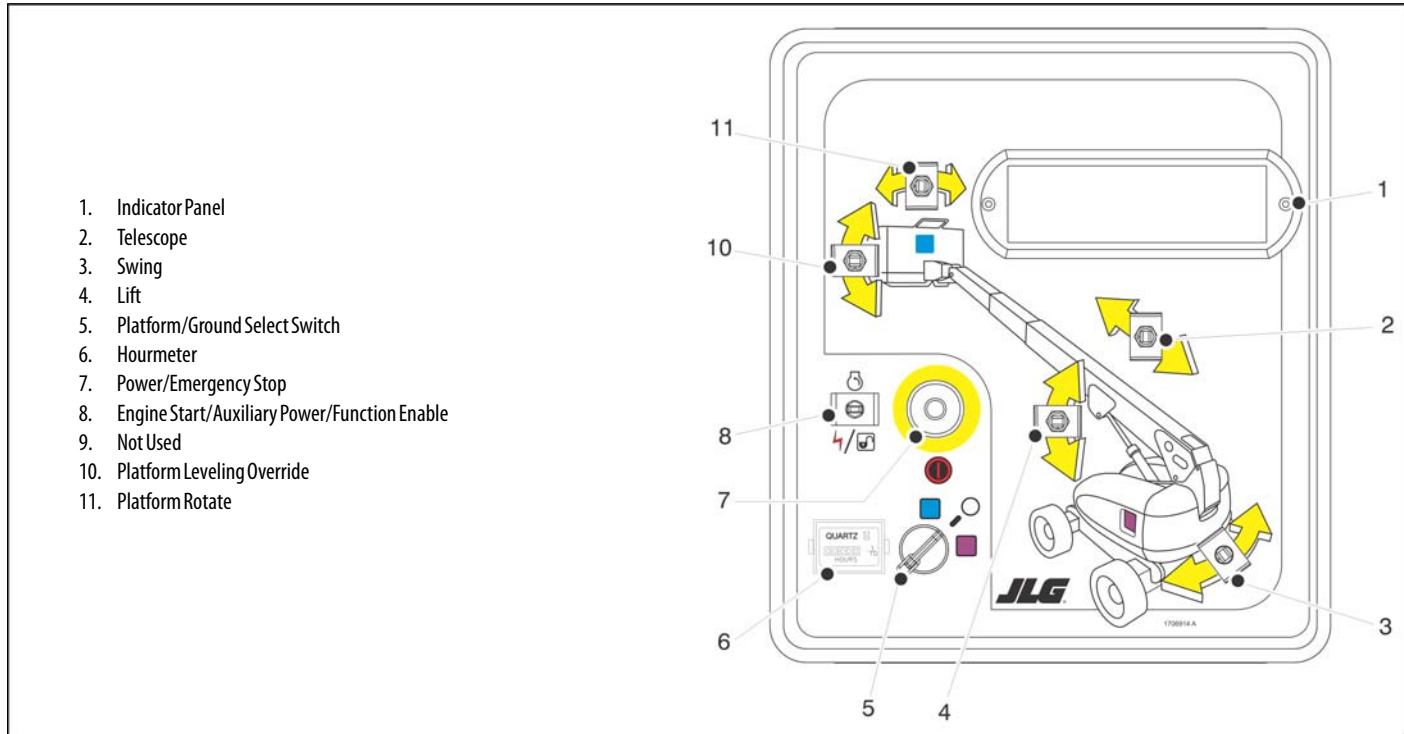

**Figure 3-1. Ground Control Console - 800S**

## SECTION 3 - MACHINE CONTROLS AND INDICATORS

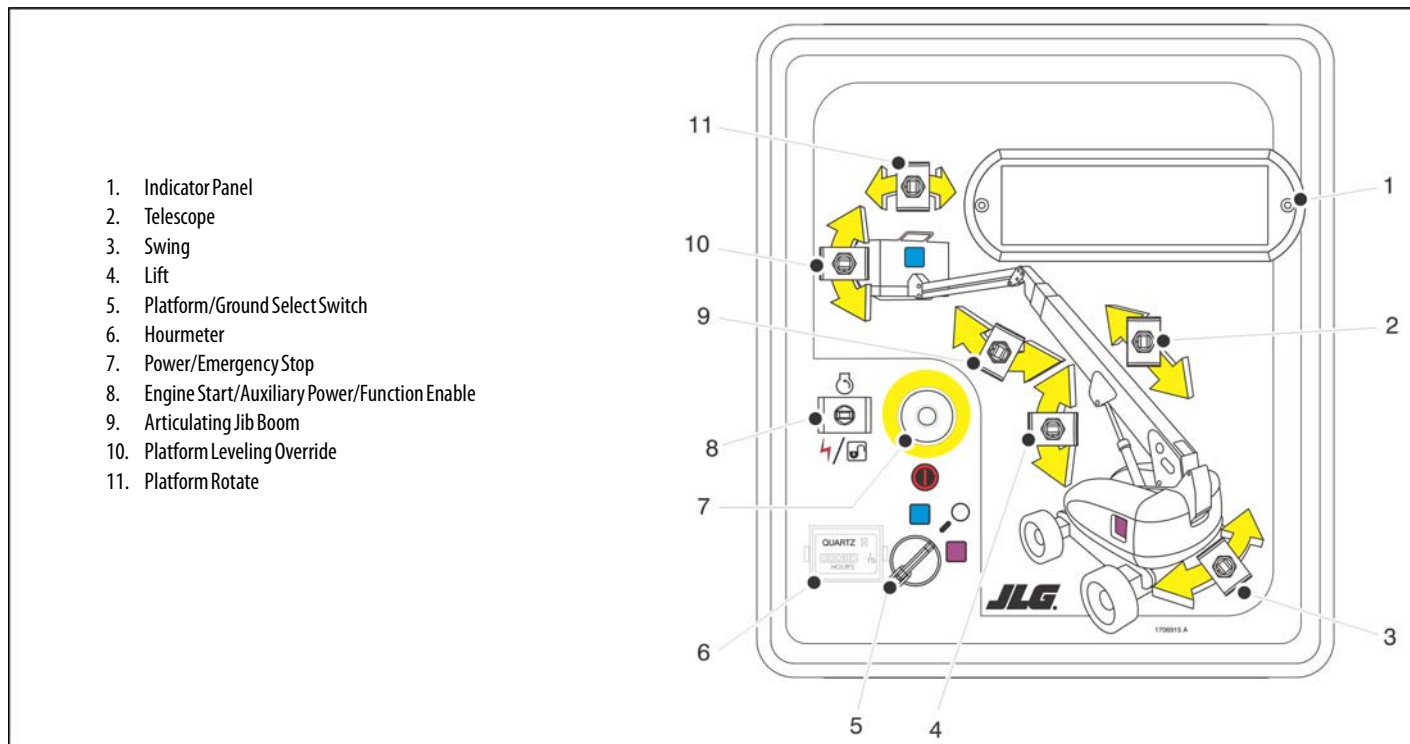
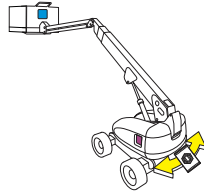

Figure 3-1. Ground Control Console - 860SJ

### 3. Swing Control

Provides 360 degrees continuous turntable rotation.



### 4. Lift Control

Provides raising and lowering of the boom.

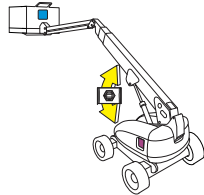

**NOTE:** When the Platform/Ground Select Switch is in the center position, power is shut off to the controls at both operating consoles. Remove the key to prevent the controls from being actuated. The key is removable in the platform position on CE specification machines. The key must be available to ground personnel in the event of an emergency.



### 5. Platform/Ground Select Switch

The three position, key operated switch supplies power to the platform control console when positioned to Platform. With the switch key turned to the Ground position only ground controls are operable.

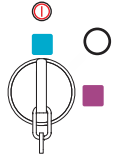

## SECTION 3 - MACHINE CONTROLS AND INDICATORS

### 6. Hourmeter

Registers the amount of time the machine has been in use, with engine running. By connecting into the oil pressure circuit of the engine, only engine run hours are recorded. The hourmeter registers up to 9,999.9 hours and cannot be reset.

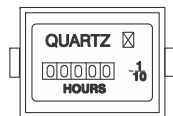

**NOTE:** When Power/Emergency Stop switch is in the "On" position and engine is not running, an alarm will sound, indicating Ignition is "On".

### **CAUTION**

**WHEN THE MACHINE IS SHUT DOWN THE MASTER/EMERGENCY STOP SWITCH MUST BE POSITIONED TO THE "OFF" POSITION TO PREVENT DRAINING THE BATTERY.**

**NOTE:** On machines with diesel engines, when Glow Plug Indicator is lighted (Yellow), wait until light goes out before cranking engine.

### 7. Power/Emergency Stop Switch

A two-position red mushroom shaped switch supplies power to Platform/Ground Select switch when pulled out (on). When pushed in (off), power is shut off to the Platform/Ground Select switch.



### 8. Engine Start/Auxiliary Power Switch

or

Engine Start/ Auxiliary Power Switch /Function Enable.

To start the engine, the switch must be held "Up" until the engine starts.



To use auxiliary power, the switch must be held "Down" for duration of auxiliary pump use. Aux power can only be used if the engine is not running.



If equipped, the enable switch must be held "Down" to enable all boom controls when the engine is running.



**NOTE:** Auxiliary power only works if there is no engine oil pressure, and is disabled if engine is running.

**NOTE:** Functions will operate at a slower than normal rate because of the lesser flow of hydraulic fluid delivered.

### **CAUTION**

**WHEN USING AUXILIARY POWER, DO NOT OPERATE MORE THAN ONE FUNCTION AT A TIME. (SIMULTANEOUS OPERATION CAN OVERLOAD THE AUXILIARY PUMP.)**

### 9. Jib (If Equipped)

This switch provides raising and lowering of the jib.

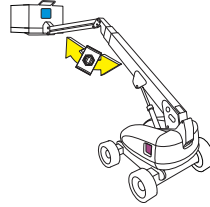

### **⚠ WARNING**

**ONLY USE THE PLATFORM LEVELING OVERRIDE FUNCTION FOR SLIGHT LEVELING OF THE PLATFORM. INCORRECT USE COULD CAUSE THE LOAD/OCCUPANT TO SHIFT OR FALL. FAILURE TO DO SO COULD RESULT IN DEATH OR SERIOUS INJURY.**

### 10. Platform Leveling Override

A three position switch allows the operator to adjust the automatic self leveling system. This switch is used to adjust platform level in situations such as ascending/descending a grade.

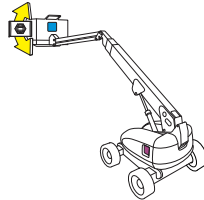

### 11. Platform Rotate

Provides rotation of the platform.

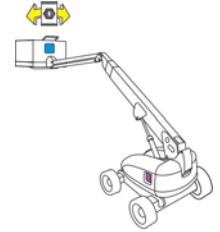

### Ground Control Indicator Panel

(See Figure 3-2., Ground Control Indicator Panel.)

**1. No Alternator Output Indicator**

Indicates a problem in the charging circuit, and service is required.



**2. Engine Oil Pressure Indicator**

Indicates that engine oil pressure is below normal and service is required.



**3. High Engine Coolant Temperature Indicator (Liquid Cooled Engines)**

Indicates that engine coolant temperature is abnormally high and service is required.



**4. Engine Oil Temperature Indicator (Deutz, If Equipped)**

Indicates that the temperature of the engine oil, which also serves as engine coolant, is abnormally high and service is required.



**5. Malfunction Indicator**

Indicates that the JLG Control System has detected a malfunction and a Diagnostic Trouble Code has been set. Refer to the Service Manual for instructions concerning the trouble codes and trouble code retrieval.



The malfunction indicator light will illuminate for 2-3 seconds when the key is positioned to the on position to act as a self test.

**6. Glow Plug/ Wait to Start Indicator**

Indicates the glow plugs are on. The glow plugs are automatically turned on with the ignition circuit and remain on for approximately seven seconds. Start the engine only after the light goes out.





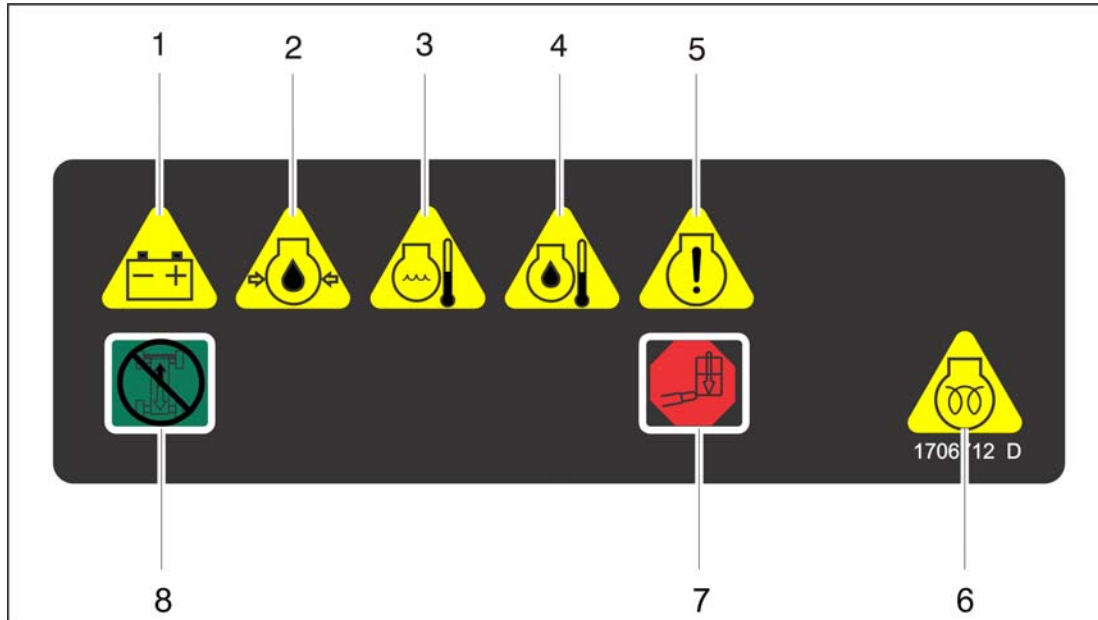

- |                         |                            |                            |
|-------------------------|----------------------------|----------------------------|
| 1. No Alternator Output | 4. Engine Oil Temp.        | 7. Platform Overload       |
| 2. Engine Oil Pressure  | 5. Malfunction Indicator   | 8. Drive and Steer Disable |
| 3. Engine Water Temp.   | 6. Glow Plug/Wait to Start |                            |

**Figure 3-2. Ground Control Indicator Panel**

## SECTION 3 - MACHINE CONTROLS AND INDICATORS

### 7. Platform Overload Indicator. (If Equipped)

Indicates the platform has been overloaded.



### 8. Drive and Steer Disable Indicator (If equipped)

Indicates the Drive and Steer Disable function has been activated.



## Platform Console

(See Figure 3-3., Platform Console)

### **⚠ WARNING**

**TO AVOID SERIOUS INJURY, DO NOT OPERATE MACHINE IF ANY CONTROL LEVERS OR TOGGLE SWITCHES CONTROLLING PLATFORM MOVEMENT DO NOT RETURN TO THE OFF OR NEUTRAL POSITION WHEN RELEASED.**

#### 1. Drive Speed/Torque Select

The machine has a two position switch - The forward position gives maximum drive speed. The back position gives maximum torque for rough terrain and climbing grades.

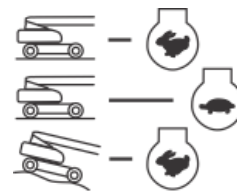

### 2. Steer Select (If Equipped)

When equipped with four wheel steering, the action of the steering system is operator selectable. The center switch position gives conventional front wheel steering with the rear wheels unaffected. This is for normal driving at maximum speeds. The forward position is for “crab” steering. When in this mode both front and rear axles steer in the same direction, which allows the chassis to move sideways as it goes forward. This can be used for positioning the machine in aisle ways or against buildings. The back switch position is for “coordinated” steering. In this mode the front and rear axles steer in the opposite directions to produce the tightest turning circle for maneuvering in confined areas.

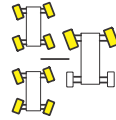

To re-synchronize the front and rear axles, position the rear drive wheels to the forward drive position by selecting either crab or compound steer, then select front steer (center switch position) to operate the normal steering function.

### **⚠ WARNING**

**ONLY USE THE PLATFORM LEVELING OVERRIDE FUNCTION FOR SLIGHT LEVELING OF THE PLATFORM. INCORRECT USE COULD CAUSE THE LOAD/OCCUPANTS TO SHIFT OR FALL. FAILURE TO DO SO COULD RESULT IN DEATH OR SERIOUS INJURY.**

### 3. Platform Leveling Override

A three position switch allows the operator to adjust the automatic self leveling system. This switch is used to adjust platform level in situations such as ascending/descending a grade.

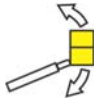

### 4. Horn

A push-type Horn switch supplies electrical power to an audible warning device when pressed.



### 5. Power/Emergency Stop Switch

A two-position red mushroom shaped switch furnishes power to Platform Controls when pulled out (on). When pushed in (off), power is shut off to the platform functions.



## SECTION 3 - MACHINE CONTROLS AND INDICATORS

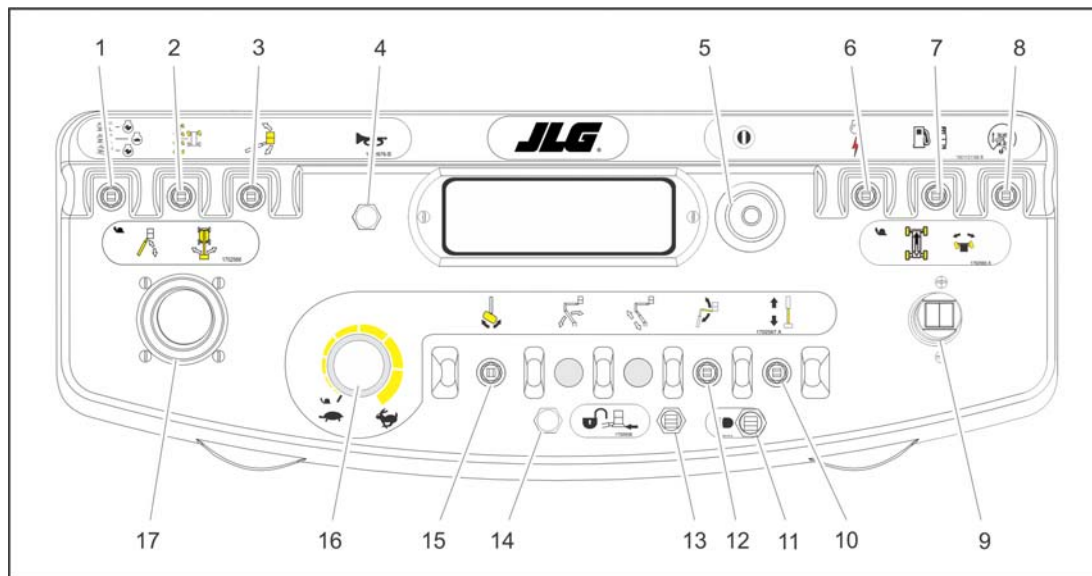

- |                               |                               |                         |                            |
|-------------------------------|-------------------------------|-------------------------|----------------------------|
| 1. Drive Speed /Torque Select | 6. Engine Start/ Aux Power    | 10. Telescope           | 14. Soft Touch Indicator   |
| 2. Steer Select               | 7. Fuel Select                | 11. Lights              | 15. Platform Rotate        |
| 3. Platform Level Override    | 8. Drive Orientation Override | 12. Jib (860SJ)         | 16. Function Speed Control |
| 4. Horn                       | 9. Drive/Steer                | 13. Soft Touch Override | 17. Main Lift / Swing      |
| 5. Power/Emergency Stop       |                               |                         |                            |

**Figure 3-3. Platform Console**

### 6. Engine Start/Auxiliary Power



When pushed forward, the switch energizes the starter motor to start the engine.

The Auxiliary Power control switch energizes the electrically operated hydraulic pump. (Switch must be held on for duration of auxiliary pump use.)



The auxiliary pump functions to provide sufficient oil flow to operate the basic machine functions should the main pump or engine fail. The auxiliary pump will operate boom lift, telescope and swing.

### 7. Fuel Select (Dual Fuel Engine Only) (If Equipped)



Gasoline or liquid propane fuel may be selected by moving the switch to the appropriate position. It is unnecessary to purge the fuel system before switching fuels, so there is no waiting period when switching fuels while the engine is running.

### 8. Drive Orientation Override



When the boom is swung over the rear tires or further in either direction, the Drive Orientation indicator will illuminate when the drive function is selected. Push and release the switch, and within 3 seconds move the Drive/Steer control to activate drive or steer. Before driving, locate the black/white orientation arrows on both the chassis and the platform controls. Move the drive controls in a direction matching the directional arrows.

## SECTION 3 - MACHINE CONTROLS AND INDICATORS

**NOTE:** Lift, Swing, and Drive control levers are spring-loaded and will automatically return to neutral (off) position when released.

### **⚠ WARNING**

**TO AVOID SERIOUS INJURY, DO NOT OPERATE MACHINE IF ANY CONTROL LEVERS OR TOGGLE SWITCHES CONTROLLING PLATFORM MOVEMENT DO NOT RETURN TO THE OFF OR NEUTRAL POSITION WHEN RELEASED.**

**NOTE:** To operate the Drive joystick, pull up on the lock-ring below the handle.

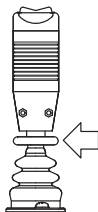

**NOTE:** The Drive joystick is spring loaded and will automatically return to neutral (off) position when released.

#### 9. Drive/Steer

Push forward to drive forward, pull back to drive in reverse. Steering is accomplished via a thumb-activated rocker switch on the end of the steer handle.

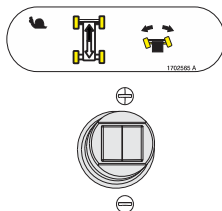

#### 10. Main Boom Telescope

Provides extension and retraction of the main boom.



#### 11. Lights (If Equipped)

This switch operates accessory lights if the machine is so equipped. The ignition switch does not have to be on to operate the lights, so care must be taken to avoid draining the battery if left unattended. The master switch and / or the ignition switch at the ground control will turn off power to all lights.



#### 12. Jib (If Equipped)

Push forward to lift up, pull back to lift down. Variable lift speed is using the Function Speed Control.



#### 13. Soft Touch Override Switch (If equipped)

This switch enables the functions that were cut out by the Soft Touch system to operate again at creep speed, allowing the operator to move the platform away from the obstacle that caused the shut-down situation.



## SECTION 3 - MACHINE CONTROLS AND INDICATORS

### 14. Soft Touch Indicator (If Equipped)

Indicates the Soft Touch bumper is against an object. All controls are cut out until the override button is pushed, at which time controls are active in the Creep Mode.



### 15. Platform Rotate

Provides rotation of the platform when positioned to the right or left.



**NOTE:** MAIN LIFT, SWING, and DRIVE control levers are spring-loaded and will automatically return to neutral (OFF) position when released.

### 16. Function Speed Control

This control affects the speed of telescope and platform rotate. Turning the knob all the way counterclockwise until it clicks puts drive, main lift and swing into creep mode.



**NOTE:** To operate the Main Boom Lift/Swing joystick, pull up on the locking ring below the handle.

**NOTE:** The Main Boom Lift/Swing joystick is spring loaded and will automatically return to neutral (off) position when released.

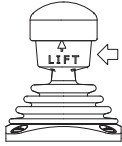

### 17. Main Lift/Swing Controller

Provides main lift and swing. Push forward to lift up, pull backward to boom down. Move right to swing right, move left to swing left. Moving the joystick activates switches to provide the functions selected.

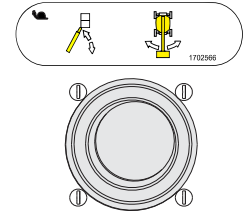

**NOTE:** Main boom lift and swing functions may be selected in combination. Maximum speed is reduced when multiple functions are selected.

## SECTION 3 - MACHINE CONTROLS AND INDICATORS

### Platform Control Indicator Panel

(See Figure 3-4., Platform Control Indicator Panel)

#### 1. Level System Fault Indicator

Indicates a fault in the electronic leveling system. The fault indicator will flash and an alarm sound. All functions will default to creep if the boom is extended more than 20 inches (51 cm) or elevated above horizontal.



### **⚠ WARNING**

**IF THE LEVEL SYSTEM FAULT INDICATOR IS ILLUMINATED, SHUT DOWN THE MACHINE, RECYCLE THE EMERGENCY STOP, AND RESTART THE MACHINE. IF THE FAULT PERSISTS, RETURN THE PLATFORM TO THE STOWED POSITION, USING MANUAL LEVELING AS REQUIRED, AND HAVE LEVELING SYSTEM REPAIRED.**

#### 2. AC Generator (If Equipped)

Indicates the generator is in operation.



#### 3. Platform Overload (If equipped)

Indicates the platform has been overloaded.



#### 4. Capacity Indicator

Indicates the maximum platform capacity for the current position of the platform. Restricted capacities are permitted at restricted platform positions (shorter boom lengths and higher boom angles).



**NOTE:** Refer to the capacity decals on the machine for restricted and unrestricted platform capacities.



### 5. Tilt Alarm Warning Light and Alarm

This illuminator indicates that the chassis is on a slope. An alarm will also sound when the chassis is on a slope and the boom is above horizontal. If lit when boom is raised or extended, retract and lower to below horizontal then reposition machine so that it is level before continuing operation. If the boom is above horizontal and the machine is on a slope, the tilt alarm warning light will illuminate and an alarm will sound and CREEP is automatically activated.



#### **WARNING**

**IF TILT WARNING LIGHT IS ILLUMINATED WHEN BOOM IS RAISED OR EXTENDED, RETRACT AND LOWER TO BELOW HORIZONTAL THEN REPOSITION MACHINE SO THAT IT IS LEVEL BEFORE EXTENDING BOOM OR RAISING BOOM ABOVE HORIZONTAL.**

**NOTE:** *In certain markets, when the tilt sensor alarm is activated the Drive function will be disabled if the boom is elevated above horizontal.*

### 6. Glow Plug/Wait to Start Indicator

Indicates the glow plugs are operating. After turning on ignition, wait until light goes out before cranking engine.



### 7. Footswitch/Enable Indicator

To operate any function, the footswitch must be depressed and the function selected within seven seconds. The enable indicator shows that the controls are enabled. If a function is not selected within seven seconds, or if a seven second lapse between ending one function and beginning the next function, the enable light will go out and the footswitch must be released and depressed again to enable the controls.



Releasing the footswitch removes power from all controls and applies the drive brakes.

#### **WARNING**

**TO AVOID SERIOUS INJURY, DO NOT REMOVE, MODIFY OR DISABLE THE FOOTSWITCH BY BLOCKING OR ANY OTHER MEANS.**

#### **WARNING**

**FOOTSWITCH MUST BE ADJUSTED IF FUNCTIONS ACTIVATE WHEN SWITCH ONLY OPERATES WITHIN LAST 1/4" OF TRAVEL, TOP OR BOTTOM.**

## SECTION 3 - MACHINE CONTROLS AND INDICATORS

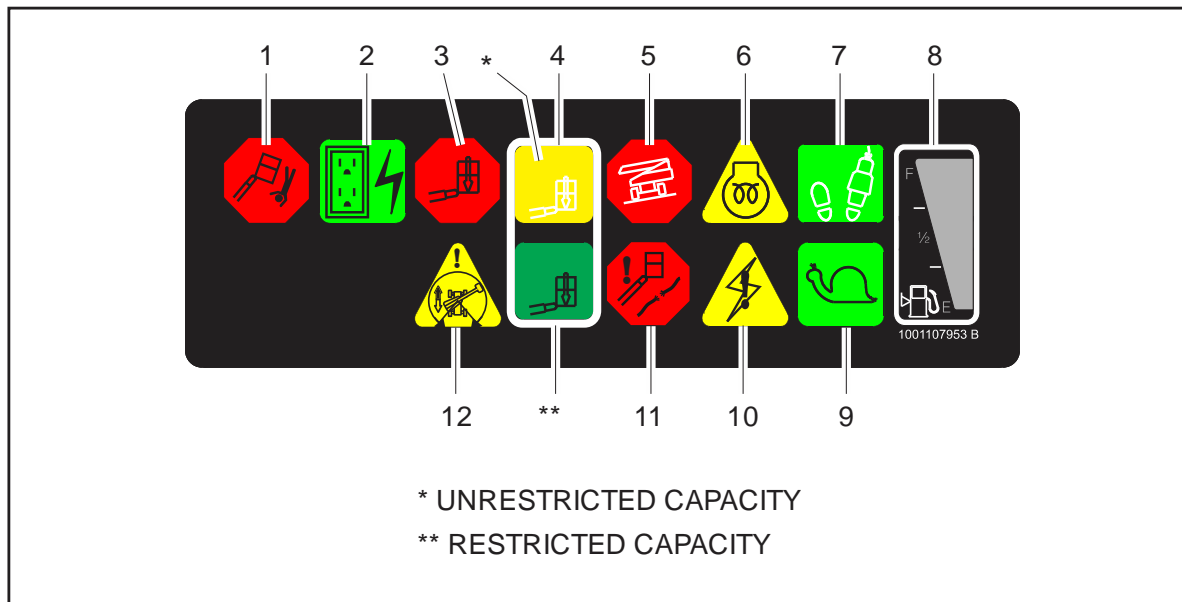

- |                 |                       |                       |
|-----------------|-----------------------|-----------------------|
| 1. Level System | 5. Tilt Alarm Warning | 9. Creep Speed        |
| 2. AC Generator | 6. Glow Plug          | 10. System Distress   |
| 3. Overload     | 7. Enable             | 11. Cable Service     |
| 4. Capacity     | 8. Fuel Level         | 12. Drive Orientation |

**Figure 3-4. Platform Control Indicator Panel**

**NOTE:** Refer to Fuel Reserve/Shut-Off System in Section 4 for more detailed information concerning the Low Fuel Indicator.

### 8. Fuel Level Indicator

Indicates the level of fuel in the fuel tank.

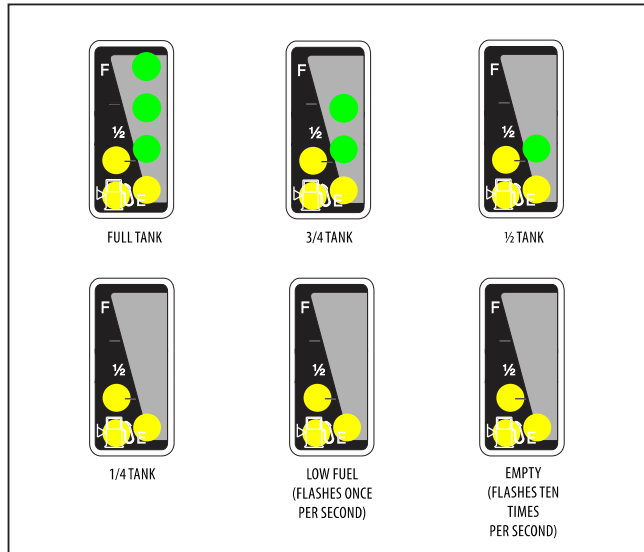

**Figure 3-5. Fuel Level Indicator**

### 9. Creep Speed Indicator

When the Function Speed Control is turned to the creep position, the indicator acts as a reminder that all functions are set to the slowest speed.



### 10. System Distress Indicator

The light indicates that the JLG Control System has detected an abnormal condition and a Diagnostic Trouble Code has been set in the system memory. Refer to the Service Manual for instructions concerning the trouble codes and trouble code retrieval.



### 11. Cable Service Indicator (If Equipped)

When illuminated, the light indicates the boom cables are loose or broken and must be repaired or adjusted immediately.



## **WARNING**

**IF THE CABLE SERVICE INDICATOR IS ILLUMINATED, RETURN THE PLATFORM TO THE STOWED POSITION, SHUT DOWN THE MACHINE, AND HAVE THE BOOM CABLES INSPECTED.**

## SECTION 3 - MACHINE CONTROLS AND INDICATORS

---

### 12. Drive Orientation Indicator

When the boom is swung beyond the rear drive tires or further in either direction, the Drive Orientation indicator will illuminate when the drive function is selected. This is a signal for the operator to verify that the drive control is being operated in the proper direction (i.e. controls reversed situations).



## **SECTION 4. 3MACHINE OPERATION**

### **4.1 DESCRIPTION**

This machine is a self-propelled hydraulic lift equipped with a work platform on the end of an elevating and rotating boom.

The primary operator control console is in the platform. From this control console, the operator can drive and steer the machine in both forward and reverse directions. The operator can raise or lower the upper or lower boom or swing the boom to the left or right. Standard boom swing is 360 degree continuous left and right of the stowed position. The machine has a Ground Control Console which will override the Platform Control Console. Ground Controls operate Boom Lift and Swing, and are to be used in an emergency to lower the platform to the ground should the operator in the platform be unable to do so. The Ground Control is also to be used in Pre-Start Inspection.

### **4.2 OPERATING CHARACTERISTICS AND LIMITATIONS**

#### **Capacities**

The boom can be raised above horizontal with or without any load in platform, if:

1. Machine is positioned on a smooth, firm and level surface.
2. Load is within manufacturer's rated capacity.
3. All machine systems are functioning properly.
4. Proper tire pressure.
5. Machine is as originally equipped from JLG.

#### **Stability**

Machine stability is based on two (2) conditions which are called FORWARD and BACKWARD stability. The machine's position of least FORWARD stability is shown in (See Figure 4-2.), and its position of least BACKWARD stability is shown in (See Figure 4-1.)

## SECTION 4 - 3MACHINE OPERATION

### **⚠ WARNING**

TO AVOID FORWARD OR BACKWARD TIPPING, DO NOT OVERLOAD MACHINE OR OPERATE THE MACHINE ON AN OUT-OF-LEVEL SURFACE.

### 4.3 ENGINE OPERATION

**NOTE:** Initial starting should always be performed from the Ground Control console.

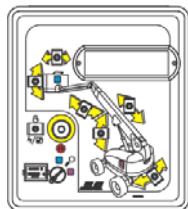

### Starting Procedure

### **⚠ CAUTION**

IF ENGINE FAILS TO START PROMPTLY, DO NOT CRANK FOR AN EXTENDED TIME. SHOULD ENGINE FAIL TO START AGAIN, ALLOW STARTER TO "COOL OFF" FOR 2-3 MINUTES. IF ENGINE FAILS AFTER SEVERAL ATTEMPTS, REFER TO ENGINE MAINTENANCE MANUAL.

**NOTE:** Diesel engines only: After turning on ignition, operator must wait until glow plug indicator light goes out before cranking engine.



1. Turn key of Platform/Ground Select switch to Ground.



2. Pull the Power/Emergency Stop switch to On.



3. Push the Engine Start switch until engine starts.



### **⚠ CAUTION**

ALLOW ENGINE TO WARM-UP FOR A FEW MINUTES AT LOW SPEED BEFORE APPLYING ANY LOAD.

4. After engine has had sufficient time to warm up, push in the Power/Emergency Stop switch and shut engine off.



5. Turn Platform/Ground Select switch to Platform.



- From Platform, pull Power/Emergency Stop switch out.

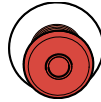

- Push the Engine Start switch until engine starts.



**NOTE:** Footswitch must be in released (up) position before starter will operate. If starter operates with footswitch in the depressed position, DO NOT OPERATE MACHINE.

## Shutdown Procedure

### **CAUTION**

**IF AN ENGINE MALFUNCTION CAUSES AN UNSCHEDULED SHUTDOWN, DETERMINE THE CAUSE AND CORRECT IT BEFORE RESTARTING THE ENGINE.**

- Remove all load and allow engine to operate at low speed for 3-5 minutes; this allows further reduction of internal engine temperature.
- Push Power/Emergency Stop switch in.



- Turn Platform/Ground Select switch to Off.

Refer to Engine Manufacturer's manual for detailed information.



## Fuel Reserve / Shut-Off System

**NOTE:** Reference the Service and Maintenance Manual along with a qualified JLG Mechanic to verify your machine setup.

The Fuel Shutoff System monitors the fuel in the tank and senses when the fuel level is getting low. The JLG Control System automatically shuts the engine down before the fuel tank is emptied unless the machine is set up for Engine Restart.

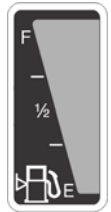

If fuel level reaches the Empty range, the Low Fuel light will begin to flash once a second and there will be approximately 60 minutes of engine run time left. If the system is in this condition and automatically shuts down the engine or if the operator manually shuts down the engine before the 60 minute run time is complete, the Low Fuel light will flash 10 times a second and the engine will react according to machine setup. Setup options are as follows:

- Engine One Restart - When the engine shuts down, the operator will be permitted to cycle power and restart the engine once with approximately 2 minutes of run time.

## SECTION 4 - 3MACHINE OPERATION

After the 2 minute run time is complete or if the engine is shut down by the operator prior to the completion of the 2 minute run time, it cannot be restarted until fuel is added to the tank.

- Engine Restart - When the engine shuts down, the operator will be permitted to cycle power and restart the engine for approximately 2 minutes of run time. After the 2 minutes of run time is complete, the operator may cycle power and restart the engine for an additional 2 minutes of run time. The operator can repeat this process until there is no more fuel available.
- Engine Stop - When the engine shuts down, no restarts will be permitted until fuel is added to the tank.

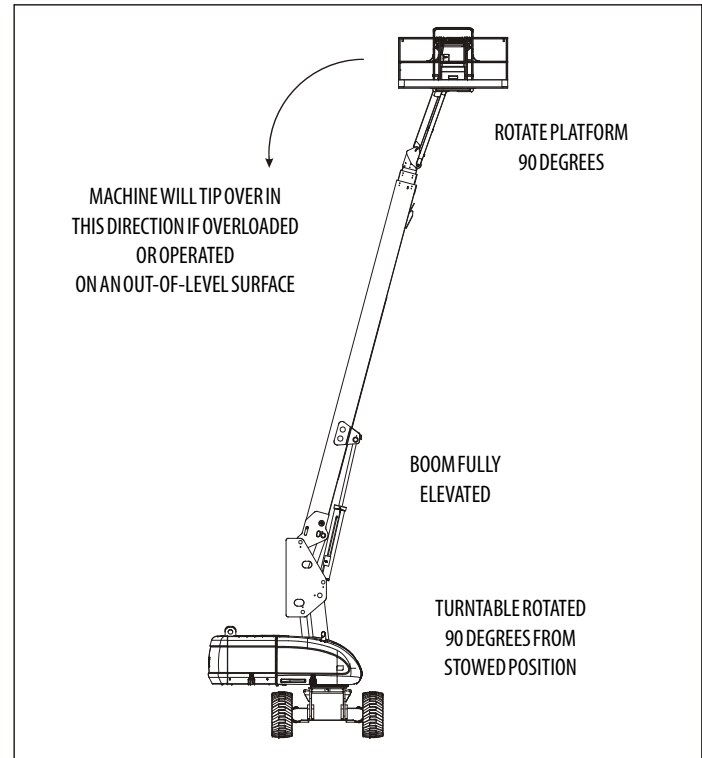
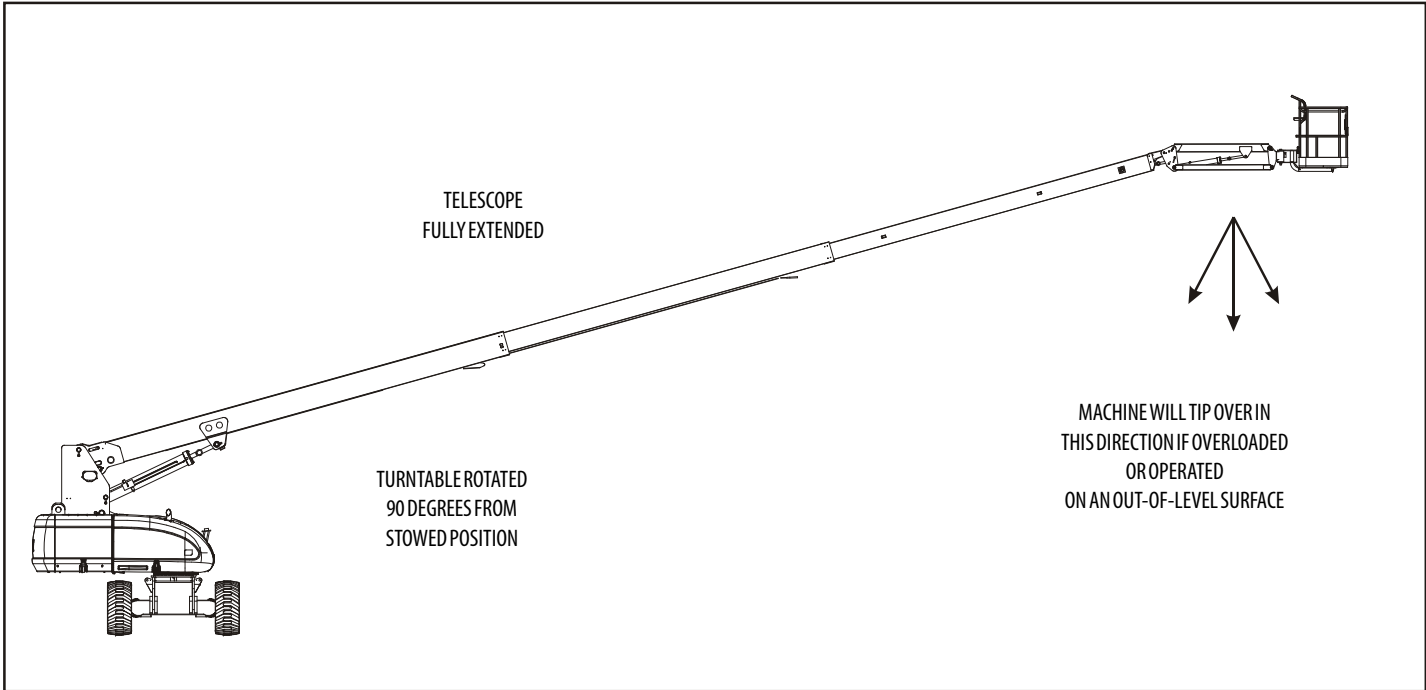

Figure 4-1. Position of Least Backward Stability





**Figure 4-2. Position of Least Forward Stability**

### 4.4 TRAVELING (DRIVING)

**NOTE:** When the upper boom is raised approximately 11 degrees above horizontal, the high drive function will automatically be in low drive.

**NOTE:** Refer to the Operating Specifications table for Gradeability and Sideslope ratings.

*All ratings for Gradeability and Sideslope are based upon the machine's boom being in the stowed position, fully lowered, and retracted.*

Traveling is limited by two factors:

1. Gradeability, which is the percent of grade of the incline the machine can climb.
2. Sideslope, which is the angle of the slope the machine can be driven across.

### **WARNING**

**DO NOT DRIVE WITH BOOM ABOVE HORIZONTAL EXCEPT ON A SMOOTH, FIRM AND LEVEL SURFACE.**

**TO AVOID LOSS OF TRAVEL CONTROL OR "TIP OVER", DO NOT DRIVE MACHINE ON GRADES EXCEEDING THOSE SPECIFIED ON THE SERIAL NUMBER PLATE.**

**BE SURE THE TURNTABLE LOCK IS ENGAGED BEFORE ANY EXTENDED TRAVELING.**

**DO NOT DRIVE ON SIDESLOPES WHICH EXCEED 5 DEGREES.**

**USE EXTREME CAUTION WHEN DRIVING IN REVERSE AND AT ALL TIMES WHEN THE PLATFORM IS ELEVATED.**

**BEFORE DRIVING, MAKE SURE BOOM IS POSITIONED OVER REAR DRIVE AXLE. IF BOOM IS OVER FRONT WHEELS, STEER AND DRIVE CONTROLS WILL BE REVERSED.**

**Traveling Forward and Reverse**

1. At Platform Controls, pull out Emergency Stop switch and activate footswitch.
2. Position Drive controller to FORWARD or REVERSE as desired.

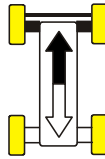

This machine is equipped with a Drive Orientation Indicator. The yellow light on the platform control console indicates that the boom is swung beyond the rear drive tires and the machine may Drive/Steer in the opposite direction from the movement of the controls. If the indicator is illuminated, operate the Drive function in the following manner:

1. Match the black and white direction arrows on both platform control panel and the chassis to determine the direction the machine will travel.
2. Push and release the Drive Orientation Override switch. Within 3 seconds, slowly move the Drive control toward the arrow matching the intended direction of machine travel. The indicator light will flash during the 3 second interval until the drive function is selected.

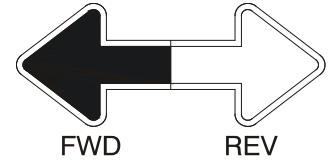

**4.5 STEERING**

Position thumb switch on Drive/Steer controller to Right for steering right, or to Left for steering left.

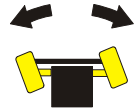

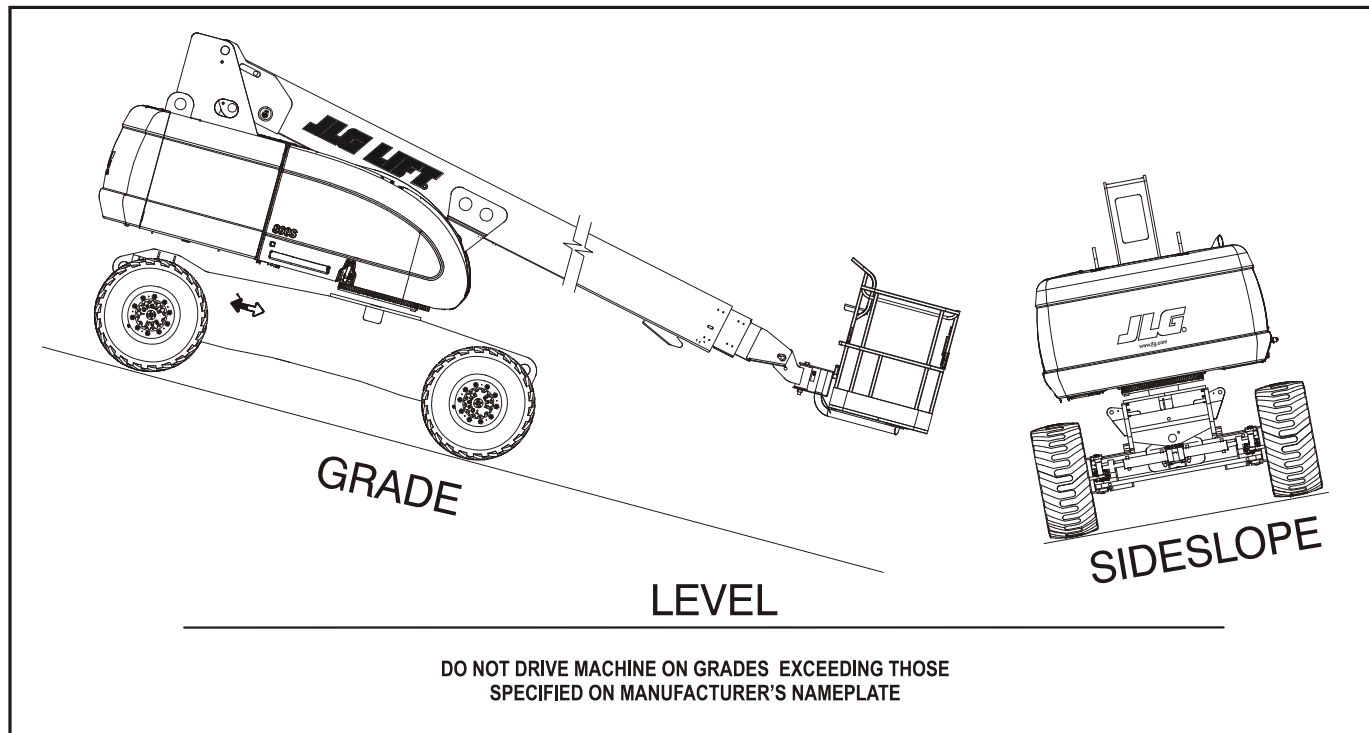

**Figure 4-3. Grade and Side Slopes**

## 4.6 PLATFORM

### Platform Level Adjustment

#### **⚠ WARNING**

ONLY USE THE PLATFORM LEVELING OVERRIDE FUNCTION FOR SLIGHT LEVELING OF THE PLATFORM. INCORRECT USE COULD CAUSE THE LOAD/OCCUPANTS TO SHIFT OR FALL. FAILURE TO DO SO COULD RESULT IN DEATH OR SERIOUS INJURY.

To Level Up or Down - Position the Platform/Level control switch Up or Down and hold until the platform is level.



### Platform Rotation

To rotate the platform to the left or right, use the Platform Rotate control switch to select the direction and hold until desired position is reached.



## 4.7 BOOM

#### **⚠ WARNING**

DO NOT SWING OR RAISE BOOM ABOVE HORIZONTAL WHEN MACHINE IS OUT OF LEVEL.

DO NOT DEPEND ON TILT ALARM AS A LEVEL INDICATOR FOR THE CHASSIS.

TO AVOID TIP OVER, LOWER PLATFORM TO GROUND LEVEL. THEN DRIVE MACHINE TO A LEVEL SURFACE BEFORE RAISING BOOM.

TO AVOID SERIOUS INJURY, DO NOT OPERATE MACHINE IF ANY CONTROL LEVER OR TOGGLE SWITCH CONTROLLING PLATFORM MOVEMENT DOES NOT RETURN TO THE 'OFF' OR NEUTRAL POSITION WHEN RELEASED.

IF THE PLATFORM DOES NOT STOP WHEN A CONTROL SWITCH OR LEVER IS RELEASED, REMOVE FOOT FROM FOOTSWITCH OR USE EMERGENCY STOP SWITCH TO STOP THE MACHINE.

### Swinging the Boom

To swing boom, use Swing control switch to select Right or Left direction.



#### **NOTICE**

**WHEN SWINGING THE BOOM MAKE SURE THERE IS AMPLE ROOM FOR THE BOOM TO CLEAR SURROUNDING WALLS, PARTITIONS AND EQUIPMENT.**

**NOTE:** *On CE Market machines, when boom functions are being operated there is an interlock that prevents the use of Drive and Steer functions.*

### Raising and Lowering the Boom

To raise or lower the Boom, position the Boom Lift control to Up or Down until the desired height is reached.



### Telescoping the Main Boom

To extend or retract the boom, use the Telescope Control Switch to select In or Out movement.



### 4.8 FUNCTION SPEED CONTROL

This control affects the speed of all boom functions and Platform Rotate. Turning the knob all the way counterclockwise till it clicks places Drive in creep speed.



### 4.9 OSCILLATING AXLE LOCKOUT TEST (IF EQUIPPED)

#### **NOTICE**

**LOCKOUT SYSTEM TEST MUST BE PERFORMED QUARTERLY, ANY TIME A SYSTEM COMPONENT IS REPLACED, OR WHEN IMPROPER SYSTEM OPERATION IS SUSPECTED.**

Refer to Section 2.4, Oscillating Axle Lockout Test (If Equipped) for procedure.

## 4.10 EMERGENCY TOWING

### **⚠ WARNING**

**RUNAWAY VEHICLE/MACHINE HAZARD. MACHINE HAS NO TOWING BRAKES. TOWING VEHICLE MUST BE ABLE TO CONTROL MACHINE AT ALL TIMES. ON-HIGHWAY TOWING NOT PERMITTED. FAILURE TO FOLLOW INSTRUCTIONS COULD CAUSE SERIOUS INJURY OR DEATH.**

**MAXIMUM TOWING SPEED 5 M.P.H. (8 K.M.H.)**

**MAXIMUM TOWING GRADE 25%.**

### **⚠ CAUTION**

**DO NOT TOW MACHINE WITH ENGINE OPERATING OR DRIVE HUBS ENGAGED.**

1. Retract, lower and position boom in travel position; lock turntable.
2. Disconnect drive hubs by inverting disconnect cap.

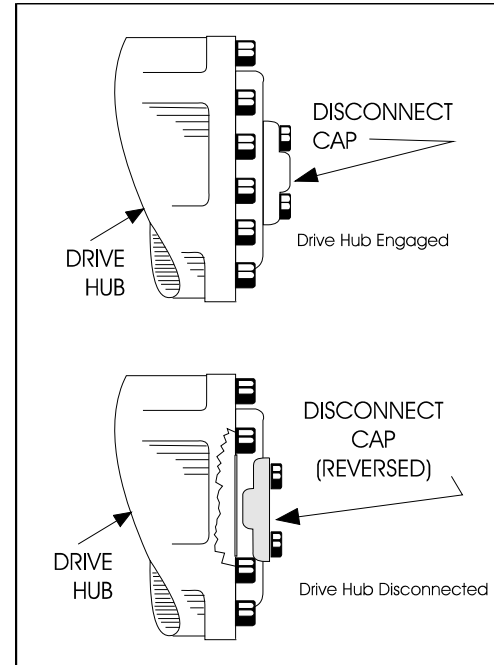

**Figure 4-4. Drive Disconnect Hub**

3. Reconnect the drive hubs by inverting the disconnect cap when towing is complete.

## **4.11 TOW BAR (IF EQUIPPED)**

### **⚠ WARNING**

**RUNAWAY VEHICLE/MACHINE HAZARD. MACHINE HAS NO TOWING BRAKES. TOWING VEHICLE MUST BE ABLE TO CONTROL MACHINE AT ALL TIMES. ON-HIGHWAY TOWING NOT PERMITTED. FAILURE TO FOLLOW INSTRUCTIONS COULD CAUSE SERIOUS INJURY OR DEATH.**

**MAXIMUM TOWING SPEED 5 M.P.H. (8 K.M.H.)**

**MAXIMUM TOWING GRADE 25%.**

Prior to towing the machine, complete the following:

### **⚠ CAUTION**

**DO NOT TOW MACHINE WITH ENGINE OPERATING OR DRIVE HUBS ENGAGED.**

1. Retract, lower and position boom in travel position; lock turntable.
2. Lower towbar and connect to towing vehicle

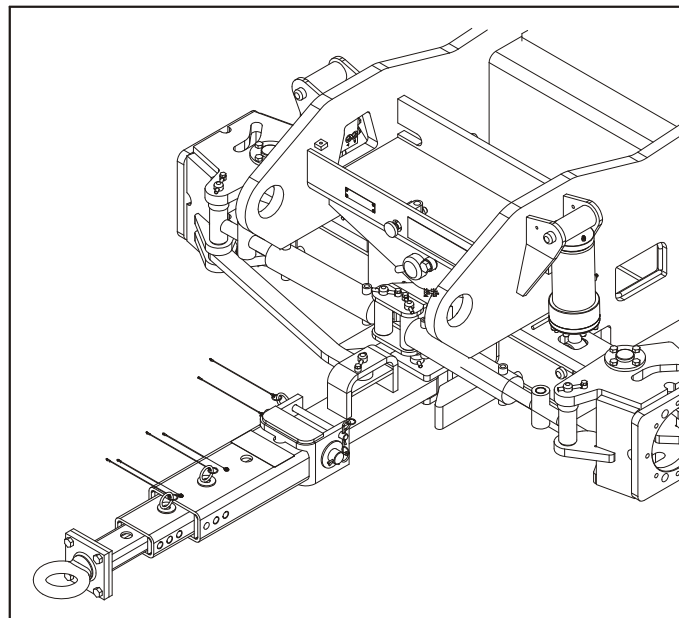

3. Disconnect drive hubs by inverting disconnect cap. Refer to Figure 4-4., Drive Disconnect Hub.
4. Position steer/tow selector valve for towing; pull valve knob OUT for towing. The machine is now in the towing mode.



**After towing the machine, complete the following:**

1. Actuate steer/tow selector valve for steering; push valve knob IN to the actuated position.
2. Reconnect drive hubs by inverting disconnect cap.
3. Disconnect towbar from towing vehicle and place it in the stowed position as shown below. The machine is now in the driving mode.

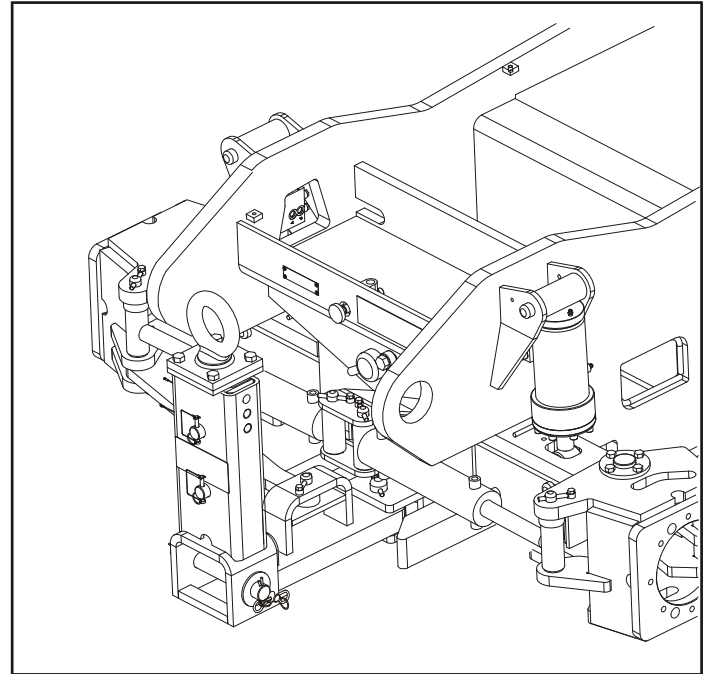

### **4.12 SHUT DOWN AND PARK**

To shut down and park the machine, the procedures are as follows:

1. Drive machine to a reasonably well protected area.
2. Ensure boom is lowered over rear drive axle.
3. Push in the Emergency Stop at Platform Controls.
4. Push in the Emergency Stop at Ground Controls. Position Platform/Ground Select switch to center OFF.
5. If necessary, cover Platform Controls to protect instruction placards, warning decals and operating controls from hostile environment.

### **4.13 LIFTING AND TIE DOWN**

#### **Lifting**

1. Call JLG Industries or weigh the individual unit to find out the Gross Vehicle Weight.
2. Place the boom in the stowed position with the turntable locked.
3. Remove all loose items from the machine.
4. Properly adjust the rigging to prevent damage to the machine and so the machine remains level.

## **Tie Down**

### **NOTICE**

**WHEN TRANSPORTING THE MACHINE, THE BOOM MUST BE FULLY LOWERED INTO THE BOOM REST.**

1. Remove all loose items from the machine.
2. When transporting an 800S/860SJ a step-deck or single-drop trailer is required. To avoid damage to the platform and to obtain proper weight distribution, load the machine onto the trailer as follows;
  - a. Position the boom over the front wheels.

### **⚠ WARNING**

**DO NOT SWING THE BOOM WITH THE MACHINE POSITIONED ON A TRAILER. TIPOVER MAY RESULT**

- b. Place the boom in the stowed position with the turntable locked.

### **NOTICE**

**DRIVE AND STEER CONTROLLERS WILL BE REVERSED WHEN THE BOOM IS POSITIONED OVER THE FRONT WHEELS.**

- c. Drive it onto the trailer with the boom and platform positioned towards the truck. Refer to Figure 4-5., Typical 800S/860SJ Transport.
3. Secure the chassis and the platform using straps or chains of adequate strength.

**SECTION 4 - 3MACHINE OPERATION**

---

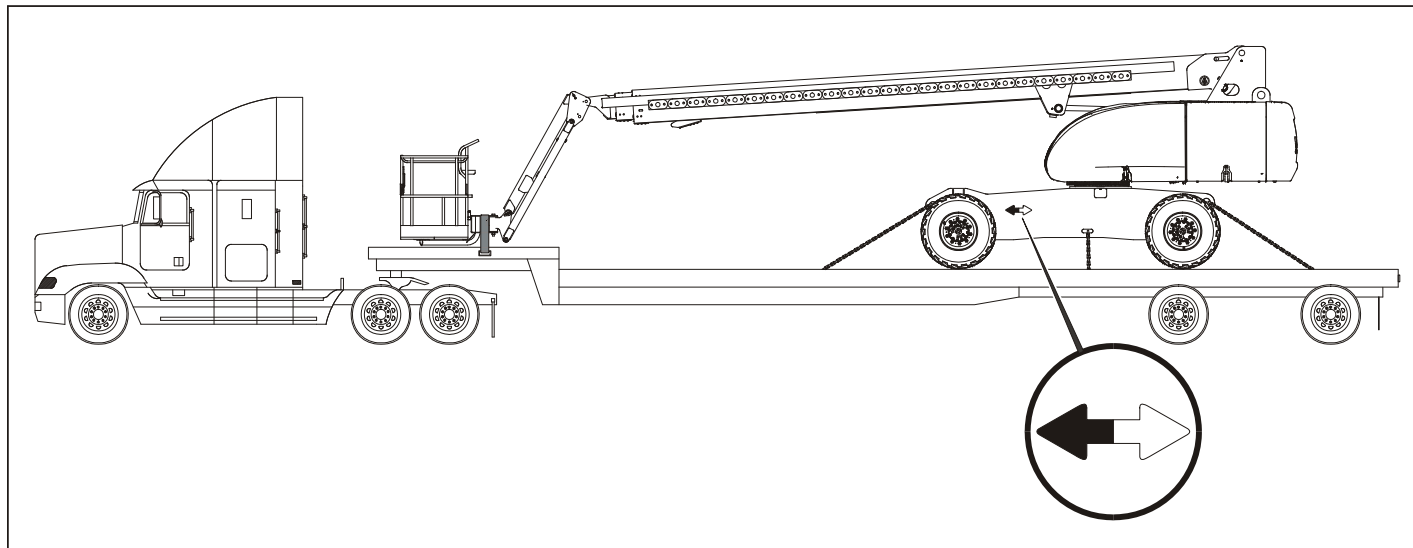

**Figure 4-5. Typical 800S/860SJ Transport**

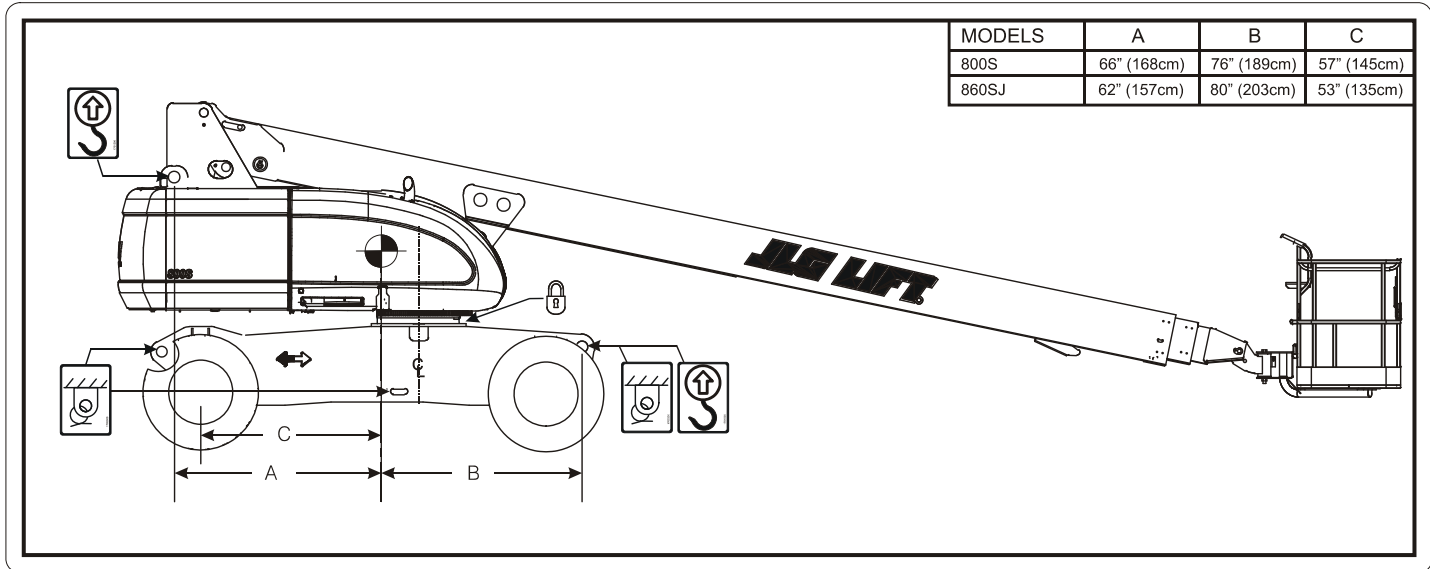

Figure 4-6. Lifting and Tie Down Chart

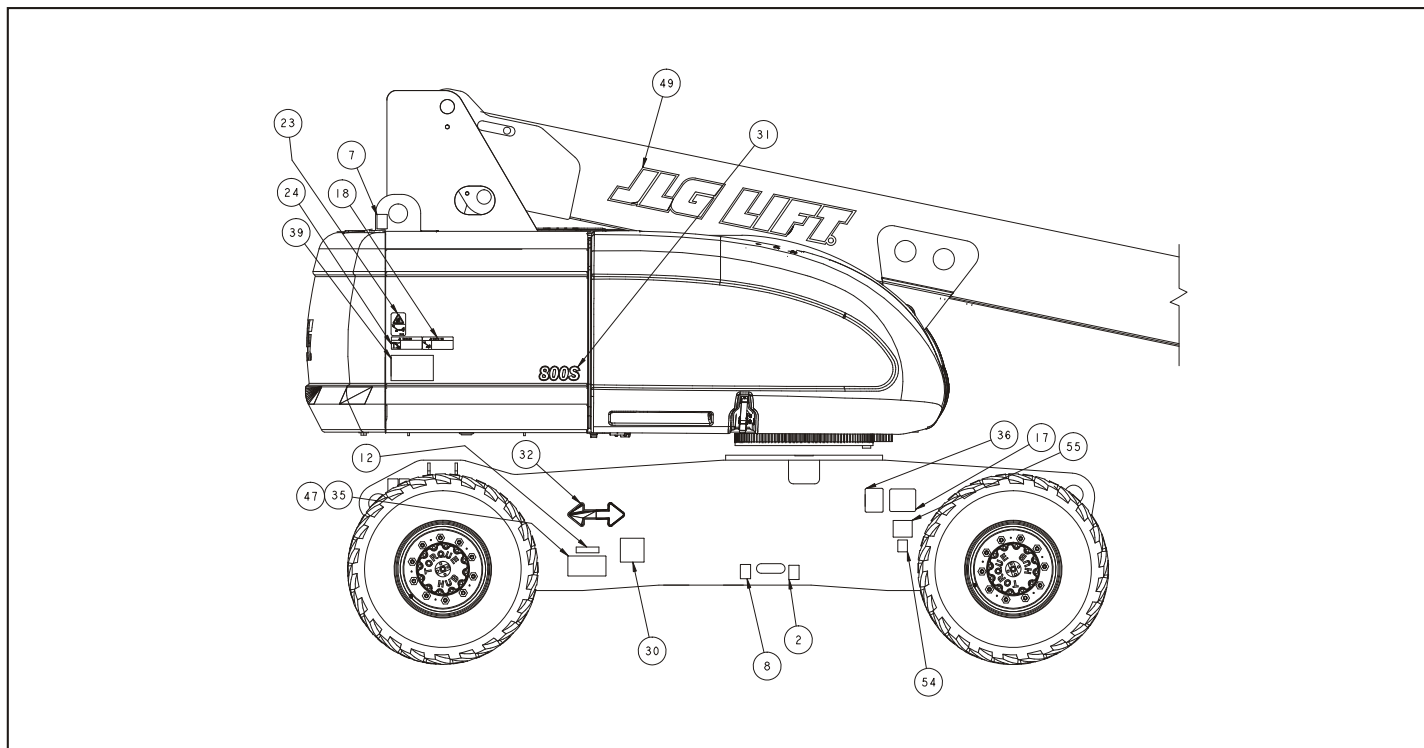

Figure 4-7. Decal Location - Sheet 1 of 5

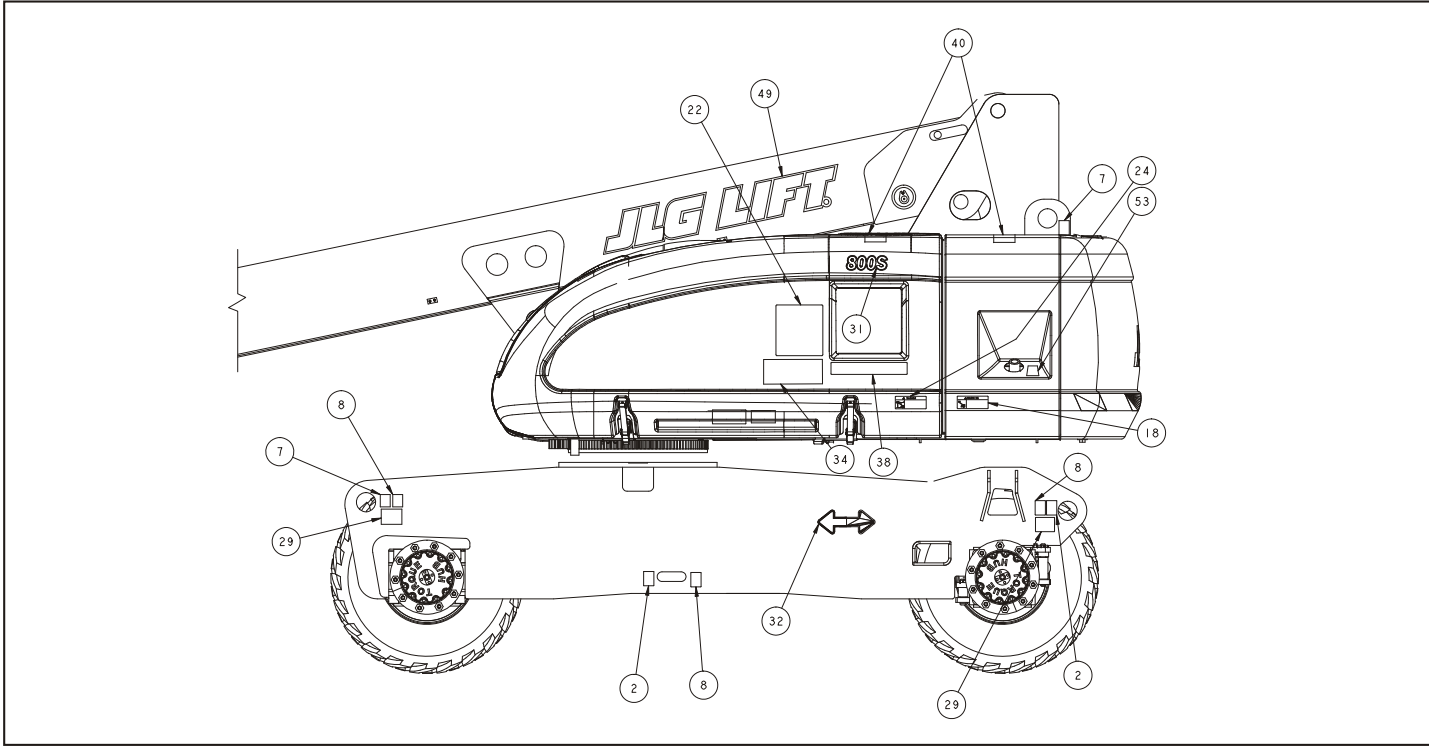

Figure 4-8. Decal Location - Sheet 2 of 5

## SECTION 4 - 3MACHINE OPERATION

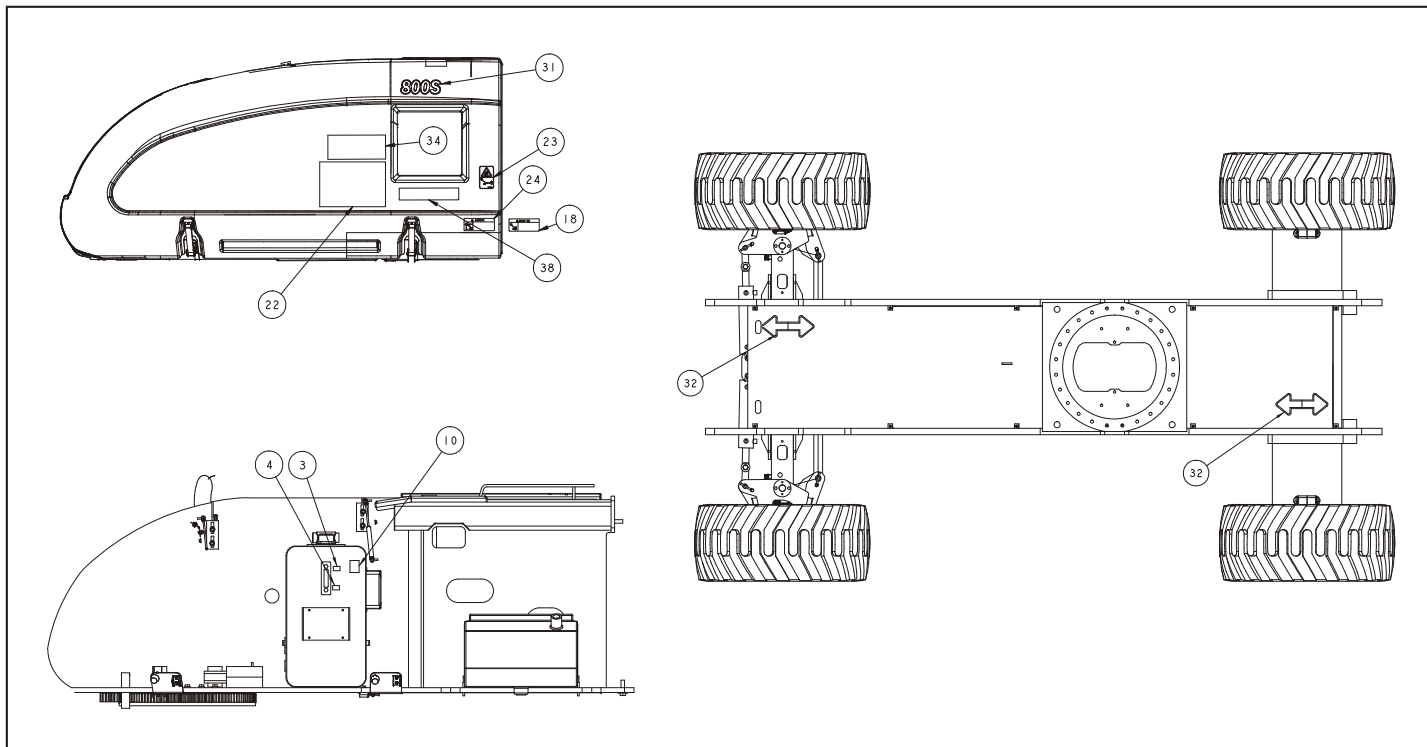

Figure 4-9. Decal Location - Sheet 3 of 5



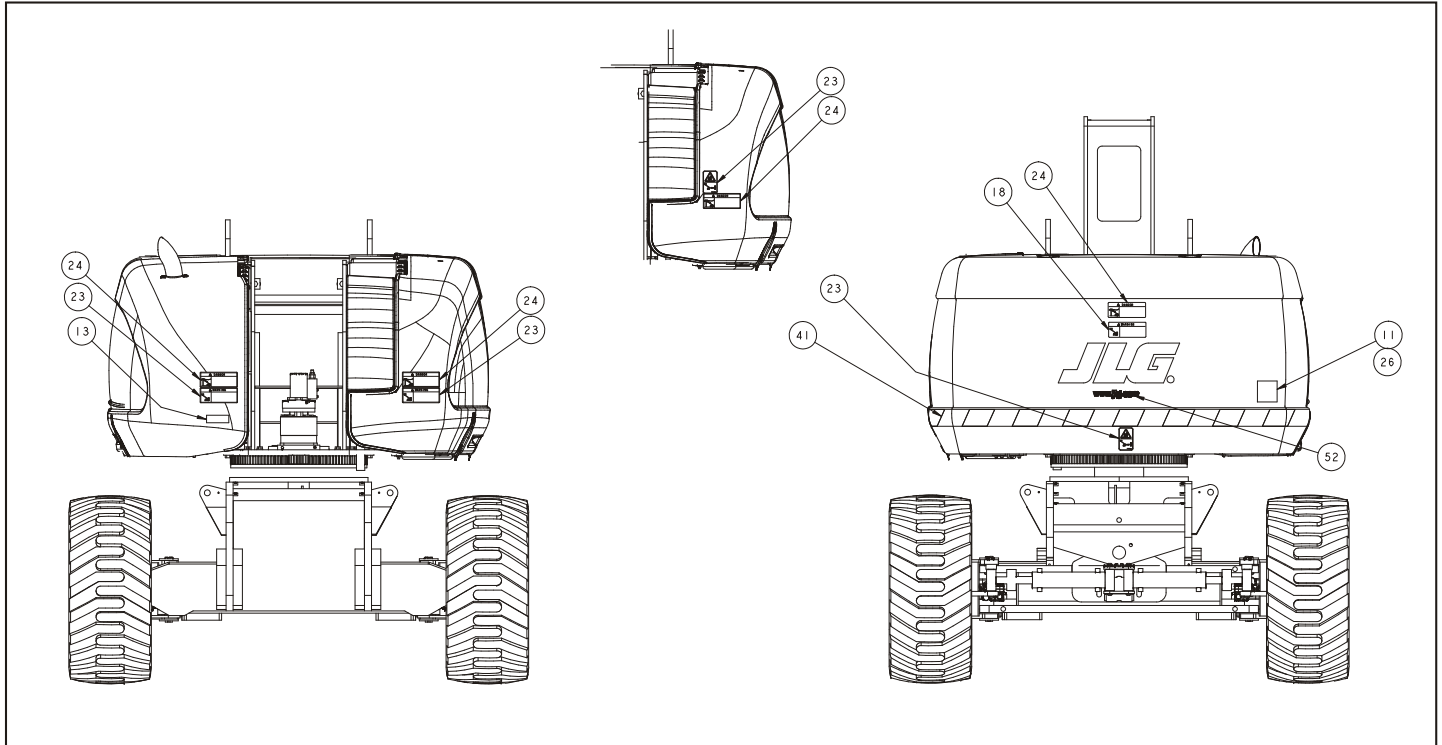

Figure 4-10. Decal Location - Sheet 4 of 5

## SECTION 4 - 3MACHINE OPERATION

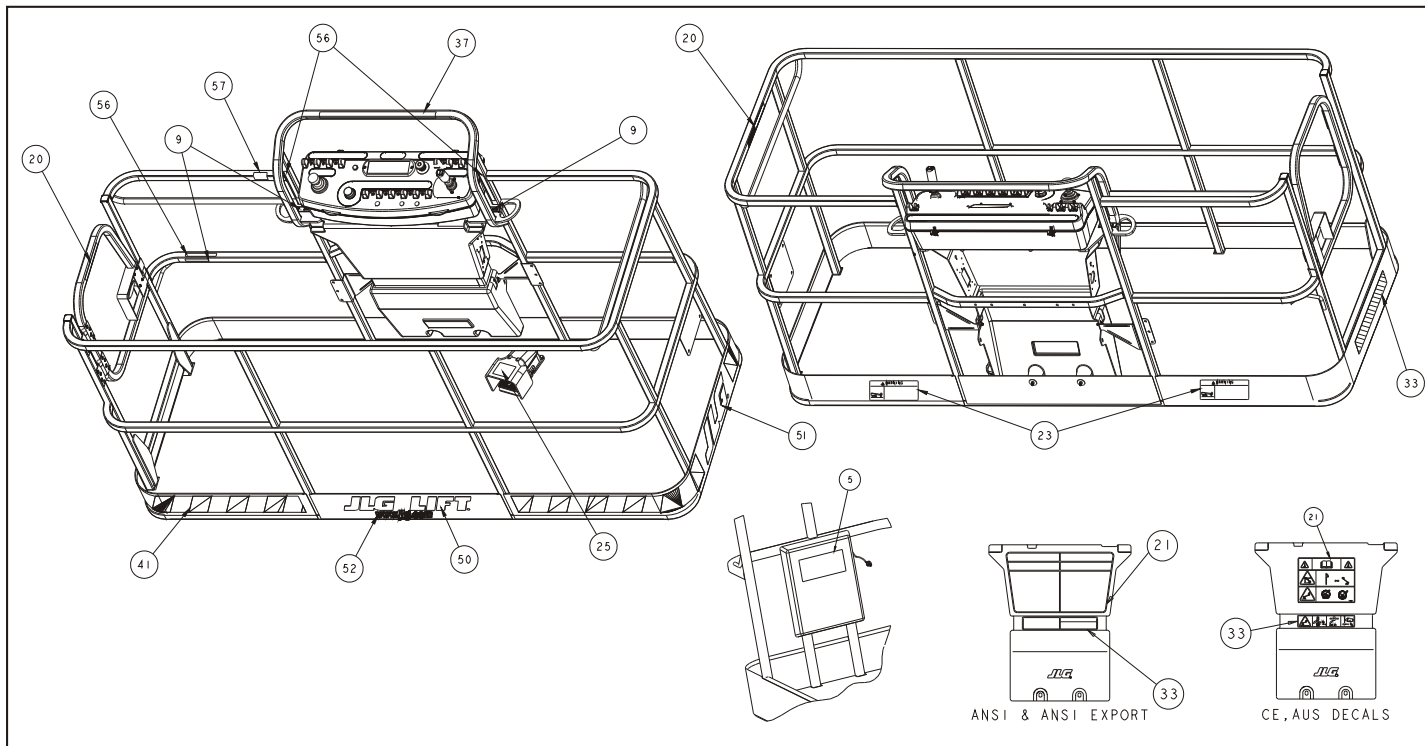

Figure 4-11. Decal Location - Sheet 5 of 5

**Table 4-1. Decal Location Legend, 800S**

<b>Item #</b>	<b>ANSI 0274499-C</b>	<b>Korean 0274501-C</b>	<b>Chinese 0274503-C</b>	<b>Spanish 0274513-C</b>	<b>Portuguese 0274505-C</b>	<b>French 0274507-C</b>	<b>CE 0274509-D</b>	<b>Japanese 0274511-C</b>	<b>Aus 1001114371-C</b>
1	--	--	--	--	--	--	--	--	--
2	1701499	1701499	1701499	1701499	1701499	1701499	1701499	1701499	1701499
3	--	--	--	--	--	--	--	--	--
4	--	--	--	--	--	--	--	--	--
5	1701509	1701509	1701509	1701509	1701509	1701509	1701509	1701509	1701509
6	--	--	--	--	--	--	--	--	--
7	1703811	1703811	1703811	1703811	1703811	1703811	1703811	1703811	1703811
8	1703814	1703814	1703814	1703814	1703814	1703814	1703814	1703814	1703814
9	1704277	1704277	1704277	1704277	1704277	1704277	1704277	1704277	1704277
10	1704412	1704412	1704412	1704412	1704412	1704412	1704412	1704412	1704412
11	--	--	--	--	--	--	1705980	--	1705980
12	--	--	--	--	--	--	--	--	--
13	--	--	--	--	--	--	--	--	--
14	--	--	--	--	--	--	--	--	--
15	--	--	--	--	--	--	--	--	--
16	--	--	--	--	--	--	--	--	--
17	--	--	--	--	--	--	--	--	--
18	1703953	1703945	1703943	1703941	1705903	1703942	--	1703944	--

## SECTION 4 - 3MACHINE OPERATION

**Table 4-1. Decal Location Legend, 800S**

Item #	ANSI 0274499-C	Korean 0274501-C	Chinese 0274503-C	Spanish 0274513-C	Portuguese 0274505-C	French 0274507-C	CE 0274509-D	Japanese 0274511-C	Aus 1001114371-C
19	--	--	--	--	--	--	--	--	--
20	1702868	1705969	1702868	1704001	1705967	1704000	--	--	--
21	1703797	1703927	1703925	1703923	1705895	1703924	1705921	1703926	1705921
22	1705336	1705345	1705348	1705917	1705896	1705347	1705822	1705344	1705822
23	1703804	1703951	1703949	1703947	1705898	1703948	1701518	1703950	1701518
24	1703805	1703939	1703937	1703935	1705897	1703936	1705961	1703938	1705961
25	3252347	1703981	1703982	1703983	1705902	1703984	1705828	1703980	1705828
26	3251813	--	--	--	--	--	--	--	--
27	--	--	--	--	--	--	--	--	--
28	--	--	--	--	--	--	--	--	--
29	1703475	1703475	1703475	1703475	1703475	1703475	1703475	1703475	1703475
30	1702631	1702631	1702631	1702631	1702631	1702631	1702631	1702631	1702631
31	1704906	1704906	1704906	1704906	1704906	1704906	1704906	1704906	1704906
32	1701501	1701501	1701501	1701501	1701501	1701501	1701501	1701501	1701501
33	1001122507	1001122200	1001121809	1001121804	1001121806	1001121802	1705978	1001121807	1705978
34	1001122515	1001122201	1001121822	1001121817	1001121819	1001121815	1705978	1001121820	1705978
35	--	--	--	--	--	--	--	--	--
36	1700584	--	--	--	--	1001131269	--	--	--

**Table 4-1. Decal Location Legend, 800S**

<b>Item #</b>	<b>ANSI 0274499-C</b>	<b>Korean 0274501-C</b>	<b>Chinese 0274503-C</b>	<b>Spanish 0274513-C</b>	<b>Portuguese 0274505-C</b>	<b>French 0274507-C</b>	<b>CE 0274509-D</b>	<b>Japanese 0274511-C</b>	<b>Aus 1001114371-C</b>
37	1001108496	1001108496	1001108496	1001108496	1001108496	1001108496	--	1001108496	--
38	1706941	1706941	1706941	1706941	1706941	1706941	--	1706941	--
39	3252781	3252781	3252781	3252781	3252781	3252781	3252781	3252781	3252781
40	1701691	1701691	1701691	1701691	1701691	1701691	1701691	1701691	1701691
41	--	--	--	--	--	--	--	--	--
42	--	--	--	--	--	--	--	--	--
43	--	--	--	--	--	--	--	--	--
44	--	--	--	--	--	--	--	--	--
45	--	--	--	--	--	--	--	--	--
46	--	--	--	--	--	--	--	--	--
47	--	--	--	--	--	--	--	--	--
48	--	--	--	--	--	--	--	--	--
49	--	--	--	--	--	--	--	--	--
50	--	--	--	--	--	--	--	--	--
51	--	--	--	--	--	--	--	--	--
52	--	--	--	--	--	--	--	--	--
53	--	--	--	--	--	--	--	--	--
54	--	--	--	--	--	--	--	--	--

## SECTION 4 - 3MACHINE OPERATION

---

**Table 4-1. Decal Location Legend, 800S**

<b>Item #</b>	<b>ANSI 0274499-C</b>	<b>Korean 0274501-C</b>	<b>Chinese 0274503-C</b>	<b>Spanish 0274513-C</b>	<b>Portuguese 0274505-C</b>	<b>French 0274507-C</b>	<b>CE 0274509-D</b>	<b>Japanese 0274511-C</b>	<b>Aus 1001114371-C</b>
55	--	--	--	--	--	--	--	--	--
56	--	--	--	--	--	--	--	--	--
57	--	--	--	--	--	--	--	--	--
58	--	--	--	--	--	--	--	--	--
59	1705351	1705427	1705430	1705910	1705905	1705429	--	1705426	--

**Table 4-2. Decal Location Legend, 860SJ**

<b>Item #</b>	<b>ANSI 0274500-C</b>	<b>Korean 0274502-C</b>	<b>Chinese 0274504-C</b>	<b>Spanish 0274514-C</b>	<b>Portuguese 0274506-C</b>	<b>French 0274508-C</b>	<b>CE 0274510-D</b>	<b>Japanese 0274512-C</b>	<b>Aus 1001114372-C</b>
1	--	--	--	--	--	--	--	--	--
2	1701499	1701499	1701499	1701499	1701499	1701499	1701499	1701499	1701499
3	--	--	--	--	--	--	--	--	--
4	--	--	--	--	--	--	--	--	--
5	1701509	1701509	1701509	1701509	1701509	1701509	1701509	1701509	1701509
6	--	--	--	--	--	--	--	--	--
7	1703811	1703811	1703811	1703811	1703811	1703811	1703811	1703811	1703811
8	1703814	1703814	1703814	1703814	1703814	1703814	1703814	1703814	1703814
9	1704277	1704277	1704277	1704277	1704277	1704277	1704277	1704277	1704277
10	1704412	1704412	1704412	1704412	1704412	1704412	1704412	1704412	1704412
11	--	--	--	--	--	--	1705980	--	1705980
12	--	--	--	--	--	1705514	--	--	--
13	--	--	--	--	--	--	--	--	--
14	--	--	--	--	--	--	--	--	--
15	--	--	--	--	--	--	--	--	--
16	--	--	--	--	--	--	--	--	--
17	1702153	--	--	--	--	--	--	--	--
18	1703953	1703945	1703943	1703941	1705903	1703942	1703942	1703944	--

## SECTION 4 - 3MACHINE OPERATION

**Table 4-2. Decal Location Legend, 860SJ**

Item #	ANSI 0274500-C	Korean 0274502-C	Chinese 0274504-C	Spanish 0274514-C	Portuguese 0274506-C	French 0274508-C	CE 0274510-D	Japanese 0274512-C	Aus 1001114372-C
19	--	--	--	--	--	--	--	--	--
20	1702868	1705969	1705968	1704001	1705967	1704000	--	--	--
21	1703797	1703927	1703925	1703923	1705895	1703924	1705921	1703926	1705921
22	1705336	1705345	1705348	1705917	1705896	1705347	1705822	1705344	1705822
23	1703804	1703951	1703949	1703947	1705898	1703948	1701518	1703950	1701518
24	1703805	1703939	1703937	1703935	1705897	1703936	1705961	1703938	1705961
25	3252347	1703981	1703982	1703983	1705902	1703984	1705828	1703980	1705828
26	--	--	--	--	--	--	--	--	--
27	--	--	--	--	--	--	--	--	--
28	--	--	--	--	--	--	--	--	--
29	1703482	1703482	1703482	1703482	1703482	1703482	1703482	1703472	1703482
30	1702631	1702631	1702631	1702631	1702631	1702631	1702631	1702631	1702631
31	1704907	1704907	1704907	1704906	1704907	1704907	1704907	1704907	1704907
32	1701501	1701501	1701501	1701501	1701501	1701501	1701501	1701501	1701501
33	1001122508	1001122509	1001122510	1001122511	1001122512	1001122513	1705978	1001122514	1705978
34	1001122516	1001122517	1001122518	1001122519	1001122520	1001122521	1705978	1001122522	1705978
35	1706948	--	--	--	--	--	--	--	--
36	1001131269	--	--	--	--	1001131269	--	--	--



**Table 4-2. Decal Location Legend, 860SJ**

<b>Item #</b>	<b>ANSI 0274500-C</b>	<b>Korean 0274502-C</b>	<b>Chinese 0274504-C</b>	<b>Spanish 0274514-C</b>	<b>Portuguese 0274506-C</b>	<b>French 0274508-C</b>	<b>CE 0274510-D</b>	<b>Japanese 0274512-C</b>	<b>Aus 1001114372-C</b>
37	1001108496	1001108496	1001108496	1001108496	1001108496	1001108496	--	1001108496	--
38	1706941	1706941	1706941	1706941	1706941	1706941	--	1706941	--
39	3252781	3252781	3252781	3252781	3252781	3252781	3252781	3252781	3252781
40	1701691	1701691	1701691	1701691	1701691	1701691	1701691	1701691	1701691
41	--	--	--	--	--	--	--	--	--
42	--	--	--	--	--	--	--	--	--
43	--	--	--	--	--	--	--	--	--
44	--	--	--	--	--	--	--	--	--
45	--	--	--	--	--	--	--	--	--
46	--	--	--	--	--	--	--	--	--
47	--	--	--	--	--	--	--	--	--
48	--	--	--	--	--	--	--	--	--
49	--	--	--	--	--	--	--	--	--
50	--	--	--	--	--	--	--	--	--
51	--	--	--	--	--	--	--	--	--
52	--	--	--	--	--	--	--	--	--
53	--	--	--	--	--	--	--	--	--
54	--	--	--	--	--	--	--	--	--

## SECTION 4 - 3MACHINE OPERATION

---

**Table 4-2. Decal Location Legend, 860SJ**

Item #	ANSI 0274500-C	Korean 0274502-C	Chinese 0274504-C	Spanish 0274514-C	Portuguese 0274506-C	French 0274508-C	CE 0274510-D	Japanese 0274512-C	Aus 1001114372-C
55	--	--	--	--	--	--	--	--	--
56	--	--	--	--	--	--	--	--	--
57	--	--	--	--	--	--	--	--	--
58	--	--	--	--	--	--	--	--	--
59	1705351	1705427	1705430	1705910	1705905	1705429	--	1705426	--

## SECTION 5. EMERGENCY PROCEDURES

### 5.1 GENERAL

This section explains the steps to be taken in case of an emergency situation while operating.

### 5.2 INCIDENT NOTIFICATION

JLG Industries, Inc. must be notified immediately of any incident involving a JLG product. Even if no injury or property damage is evident, the factory should be contacted by telephone and provided with all necessary details.

In USA:

JLG Phone: 877-JLG-SAFE (554-7233)

Outside USA:

240-420-2661

E-mail:

ProductSafety@JLG.com

Failure to notify the manufacturer of an incident involving a JLG Industries product within 48 hours of such an occurrence may void any warranty consideration on that particular machine.

### **NOTICE**

**FOLLOWING ANY ACCIDENT, THOROUGHLY INSPECT THE MACHINE AND TEST ALL FUNCTIONS FIRST FROM THE GROUND CONTROLS, THEN FROM THE PLATFORM CONTROLS. DO NOT LIFT ABOVE 3 M (10 FT.) UNTIL YOU ARE SURE THAT ALL DAMAGE HAS BEEN REPAIRED, IF REQUIRED, AND THAT ALL CONTROLS ARE OPERATING CORRECTLY.**

### 5.3 EMERGENCY OPERATION

#### Operator Unable to Control Machine

IF THE PLATFORM OPERATOR IS PINNED, TRAPPED OR UNABLE TO OPERATE OR CONTROL MACHINE:

1. Other personnel should operate the machine from ground controls only as required.
2. Other qualified personnel on the platform may use the platform controls. DO NOT CONTINUE OPERATION IF CONTROLS DO NOT FUNCTION PROPERLY.
3. Cranes, forklift trucks or other equipment can be used to remove platform occupants and stabilize motion of the machine.

### **Platform or Boom Caught Overhead**

If the platform or boom becomes jammed or snagged in overhead structures or equipment, rescue platform occupants prior to freeing the machine.

### **Boom Movement Prevented By Boom Control System**

Lowering the boom onto an object or structure, with the boom at high angles, may cause the boom control system to prevent movement of the machine. This can include movement necessary to lift the boom off the object. Movement of the boom can be regained by observing the following:

1. Shut off the engine.
2. Rescue platform occupants prior to freeing machine.
3. Use cranes, forklifts or other equipment to stabilize motion of the machine as required.
4. From the ground control position, use the Auxiliary Power System to carefully raise the boom off the object.
5. Once clear, restart the engine and return the platform to the ground.
6. Inspect the machine for damage before continued use of the machine.

### **5.4 EMERGENCY TOWING PROCEDURES**

Towing this machine is prohibited, unless properly equipped. However, provisions for moving the machine have been incorporated. For specific procedures, refer to Section 4.

## SECTION 6. GENERAL SPECIFICATIONS & OPERATOR MAINTENANCE

### 6.1 INTRODUCTION

This section of the manual provides additional necessary information to the operator for proper operation and maintenance of this machine.

The maintenance portion of this section is intended as information to assist the machine operator to perform daily maintenance tasks only, and does not replace the more thorough Preventive Maintenance and Inspection Schedule included in the Service and Maintenance Manual.

#### Other Publications Available:

Service and Maintenance Manual .....	3121631
Illustrated Parts Manual .....	3121632

### 6.2 OPERATING SPECIFICATIONS

**Table 6-1. Operating Specifications**

Maximum Work Load (Capacity) ANSI Unrestricted: Restricted	500 lb (227 kg)  Refer to Capacity Decals on machine for restricted platform capacities
Maximum Work Load (Capacity) CE & Australia Unrestricted: Restricted	500 lb (230 kg)  Refer to Capacity Decals on machine for restricted platform capacities
Maximum Capacity - Dual Rating ANSI 800S 860SJ	1000 lb. (454 kg) 750 lb. (340 kg)
Maximum Capacity - Dual Rating CE & Australia 800S 860SJ	1000 lb. (450 kg) 750 lb. (340 kg)

## SECTION 6 - GENERAL SPECIFICATIONS & OPERATOR MAINTENANCE

**Table 6-1. Operating Specifications**

Maximum Travel Grade (Gradeability)*		
2WD		30%
4WD		45%
Maximum Travel Grade (Side Slope)*		5°
Maximum Vertical Platform Height:		
	800S - 80 ft. (24.3 m)	
	860SJ - 86 ft. (26.2 m)	
Maximum Horizontal Platform Reach		
800S		71 ft. (21.6 m)
860SJ		75 ft. (22.9 m)
Turning Radius (outside)		19.75 ft. (6.02 m)
Turning Radius (inside)		12.5 ft. (3.8 m)
Maximum Drive Speed:		3.5 mph (1.5 m/s)
Max. Hydraulic System Pressure		4500 psi (310 Bar)
Maximum Wind Speed		28 mph (12.5 m/s)
Maximum Manual Force		400 N
Electrical System Voltage		12 Volts
Gross Machine Weight (Platform Empty)		
800S	33,030 lbs. (14,982 kg)	
860SJ	36,229 lbs. (16,433 kg)	

\* With boom in stowed position

## Specifications and Performance Data

**Table 6-2. Specifications and Performance Data**

Swing		360°
Tail Swing		4'8" (1.42 m)
Platforms		36" x 72" (0.91m x 1.83m) 36" x 96" (0.91m x 2.44m)
Overall Width		8' 2" (2.48 m)
Stowed Height		
800S		9' 10.6" (3.01 m)
860SJ		10' (3.04 m)
Stowed Length		
800S		37' 3.25" (11.4 m)
860SJ		40' (12.2 m)
Wheel base		10' (3.06 m)
Ground Clearance		11" (0.28 m)
Drive Speed		
Stowed 2WD		3.0 mph (5.5 kph)
Stowed 4WD		3.5 mph (5.6 kph)
Elevated		0.75 mph (1.2 kph)
Ground Bearing Pressure - 800S		72 psi (5.06 kgm/cm <sup>2</sup> )
Ground Bearing Pressure - 860SJ		81 psi (5.7 kgm/cm <sup>2</sup> )

**Table 6-2. Specifications and Performance Data**

Max. Tire Load - 800S	17,350 lbs. (7870 kg)
Max. Tire Load - 860SJ	20,200 lbs. (9163 kg)

**Capacities**

**Table 6-3. Capacities**

Fuel Tank	Approx. 31 gallons (117 liters)
Fuel Tank (Optional)	Approx. 52.8 gallons (200 liters)
Hydraulic Tank	Approx. 40 gallons (151 liters)
Engine Oil Capacity	
Deutz D2011L04	
Cooling System	5 Quarts (4.5L)
Crankcase	11 Quarts (10.5L) w/Filter
Total Capacity	16 Quarts (15L)
Deutz TD 2.9L	2.4 Gallon (8.9L) w/Filter
GM	4.5 Quarts (4.25L) w/Filter

## SECTION 6 - GENERAL SPECIFICATIONS & OPERATOR MAINTENANCE

### Engine Data

**Table 6-4. Deutz D2011L04 Specifications**

Type	Liquid Cooled (Oil)
Fuel	Diesel
Oil Capacity	
Cooling System	5 Quarts (4.5 L)
Crankcase	11 Quarts (10.5 L) w/Filter
Total Capacity	16 Quarts (15 L)
Idle RPM	1000
Low RPM	1800
High RPM	2600
Alternator	55 Amp, belt drive
Fuel Consumption	0.88 GPH (3.33 lph)
Battery	1000 Cold Cranking Amps, 210 minutes Reserve Capacity, 12 VDC
Horsepower	61.6 @ 2600 RPM, full load

**Table 6-5. Deutz TD 2.9 Specifications**

Fuel	Ultra Low Sulfur Diesel (15 ppm)
Output	67 hp (50 kW)
Torque	173 ft.lbs. (234 Nm) @ 1800rpm
Oil Capacity (Crankcase)	2.4 Gallon (8.9 L) w/Filter
Cooling System	3.3 Gallon (12.5 L)
Low RPM	1200 ± 50 rpm
High RPM	2600 ± 50 rpm
Alternator	95 Amp
Fuel Consumption	0.65 GPH (2.48 lph)



## SECTION 6 - GENERAL SPECIFICATIONS & OPERATOR MAINTENANCE

**Table 6-6. GM 3.0L**

Fuel	Gasoline or Gasoline/LP Gas
No. of Cylinders	4
BHP	
Gasoline	83 hp @ 3000 rpm
LP	75 hp @ 3000 rpm
Bore	4.0 in. (101.6 mm)
Stroke	3.6 in. (91.44 mm)
Displacement	181 cu.in. (3.0 L, 2966 cc)
Oil Capacity w/filter	4.5 qts. (4.25 L)
Minimum Oil Pressure	
at idle	6 psi (0.4 Bar) @ 1000 rpm
Hot	18 psi (1.2 Bar) @ 2000 rpm
Compression Ratio	9.2:1
Firing Order	1-3-4-2
Max. RPM	2800

## Battery

**Table 6-7. Battery Specifications**

Voltage	12 Volt
Type	31-950
Cold Cranking Amps	950 CCA @ 0°F (-18°C)
Reserve Capacity	205 Minutes @ 80°F (27°C)

**Tires**

**Table 6-8. Tire Specifications**

Size	Type	Ply Rating	Load Range	Pressure
15-625	pneumatic	16	H	95PSI (6.5 Bar)
15-625	foam-filled	16	H	N/A
18-625	foam-filled	16	H	N/A

**Major Component Weights**

**Table 6-9. Component Weights**

Component	Pounds	Kilograms
Turntable (bare)	3700	1678
Counterweight (800S)	7000	3175
Counterweight (860SJ)	8750	3969
Upright	1050	476
Tower	685	311
Fly Boom (SJ)	472	214
Fly Boom (S)	490	222
Mid Boom (SJ)	750	340
Mid Boom (S)	740	336
Base Boom (SJ)	1400	635
Base Boom (S)	1410	640
Boom Assembly	3337	1514
Telescope Cylinder (800S)	590	268
Telescope Cylinder (860SJ)	570	259
Slave Cylinder	73	33
Torque Hub (2WD)	218	99
Tire & Wheel (pneu)	269	122
Tire & Wheel (FF)	544	247

**Hydraulic Oil**

**Table 6-10. Hydraulic Oil**

Hydraulic System Operating Temperature Range	S.A.E. Viscosity Grade
+0° to +180°F (-18° to +83°C)	10W
+0° to +210°F (-18° to +99°C)	10W-20, 10W30
+50° to +210°F (+10° to +99°C)	20W-20

**NOTE:** Hydraulic oils must have anti-wear qualities at least to API Service Classification GL-3, and sufficient chemical stability for mobile hydraulic system service. JLG Industries recommends Mobilfluid 424 hydraulic oil, which has an SAE viscosity index of 152.

**NOTE:** When temperatures remain consistently below 20 degrees F. (-7 degrees C.), JLG Industries recommends the use of Mobil DTE13.

Aside from JLG recommendations, it is not advisable to mix oils of different brands or types, as they may not contain the same required additives or be of comparable viscosities. If use of hydraulic oil other than Mobilfluid 424 is desired, contact JLG Industries for proper recommendations.

**Table 6-11. Mobilfluid 424 Specs**

SAE Grade	10W30
Gravity, API	29.0
Density, Lb/Gal. 60°F	7.35
Pour Point, Max	-46°F (-43°C)
Flash Point, Min.	442°F (228°C)
Viscosity	
Brookfield, cP at -18°C	2700
at 40°C	55 cSt
at 100°C	9.3 cSt
Viscosity Index	152

## SECTION 6 - GENERAL SPECIFICATIONS & OPERATOR MAINTENANCE

**Table 6-12. UCon Hydrolube HP-5046**

Type	Synthetic Biodegradable
Specific Gravity	1.082
Pour Point, Max	-58°F (-50°C)
pH	9.1
<b>Viscosity</b>	
at 0°C (32°F)	340 cSt (1600SUS)
at 40°C (104°F)	46 cSt (215SUS)
at 65°C (150°F)	22 cSt (106SUS)
Viscosity Index	170

**Table 6-13. Mobil DTE 13M Specs**

ISO Viscosity Grade	#32
Specific Gravity	0.877
Pour Point, Max	-40°F (-40°C)
Flash Point, Min.	330°F (166°C)
<b>Viscosity</b>	
at 40° C	33cSt
at 100° C	6.6 cSt
at 100° F	169 SUS
at 210° F	48 SUS
cp at -20° F	6,200
Viscosity Index	140

**SECTION 6 - GENERAL SPECIFICATIONS & OPERATOR MAINTENANCE**

**Table 6-14. Mobil EAL 224H Specs**

Type	Synthetic Biodegradable
ISO Viscosity Grade	32/46
Specific Gravity	.922
Pour Point, Max	-25°F (-32°C)
Flash Point, Min.	428°F (220°C)
Operating Temp.	0 to 180°F (-17 to 162°C)
Weight	7.64 lb. per gal. (0.9 kg per liter)
<b>Viscosity</b>	
at 40°C	37 cSt
at 100°C	8.4 cSt
Viscosity Index	213
<b>NOTE:</b> Must be stored above 32°F (14°C)	

**Table 6-15. Exxon Univis HVI 26 Specs**

Specific Gravity	32.1
Pour Point	-76°F (-60°C)
Flash Point	217°F (103°C)
<b>Viscosity</b>	
at 40°C	25.8 cSt
at 100°C	9.3 cSt
Viscosity Index	376
<b>NOTE:</b> Mobil/Exxon recommends that this oil be checked on a yearly basis for viscosity.	

### **6.3 SERIAL NUMBER LOCATION**

A serial number plate is affixed to the left rear side of the frame. If the serial number plate is damaged or missing, the machine serial number is stamped on the left side of the frame.

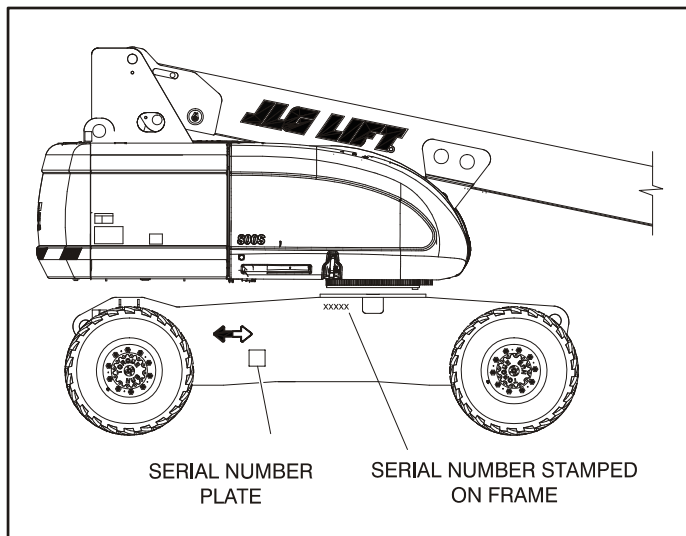

**Figure 6-1. Serial Number Locations**

# SECTION 6 - GENERAL SPECIFICATIONS & OPERATOR MAINTENANCE

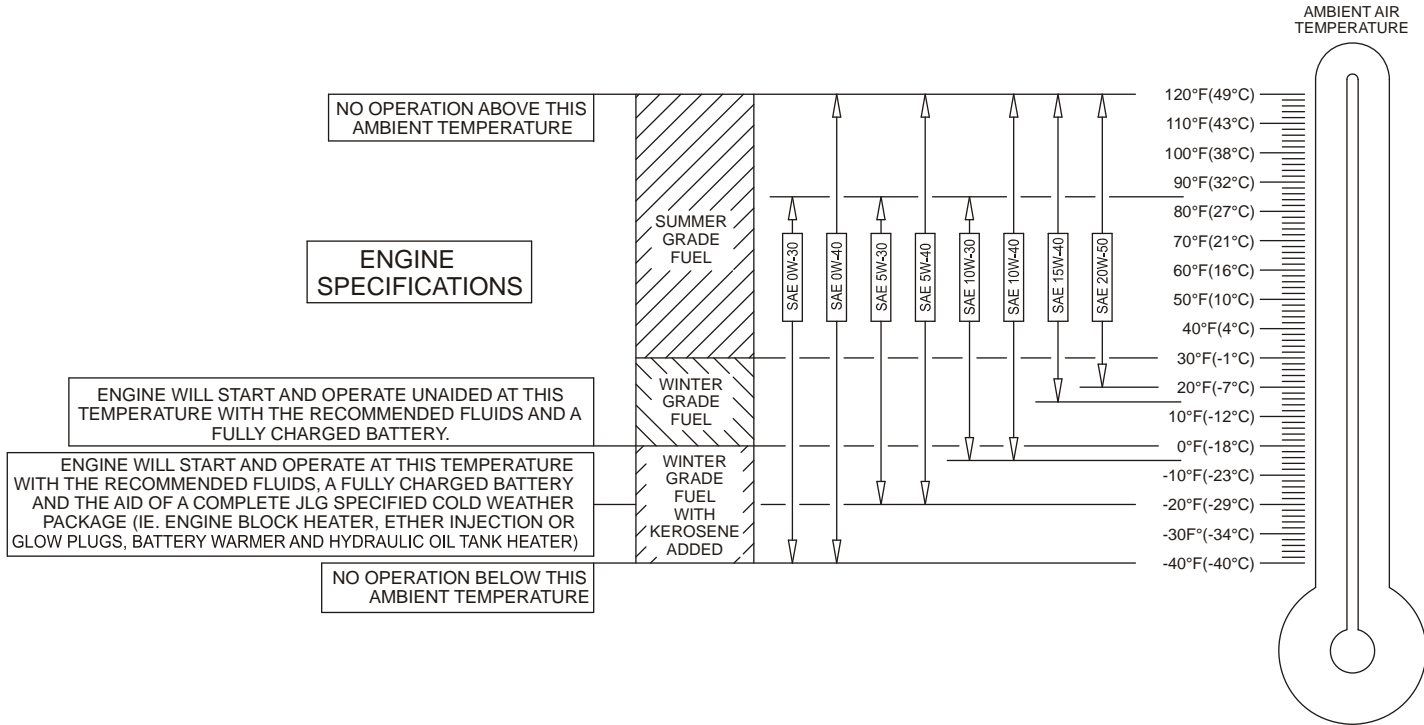

**Figure 6-2. Engine Operating Temperature Specifications - Deutz - Sheet 1 of 2**

# SECTION 6 - GENERAL SPECIFICATIONS & OPERATOR MAINTENANCE

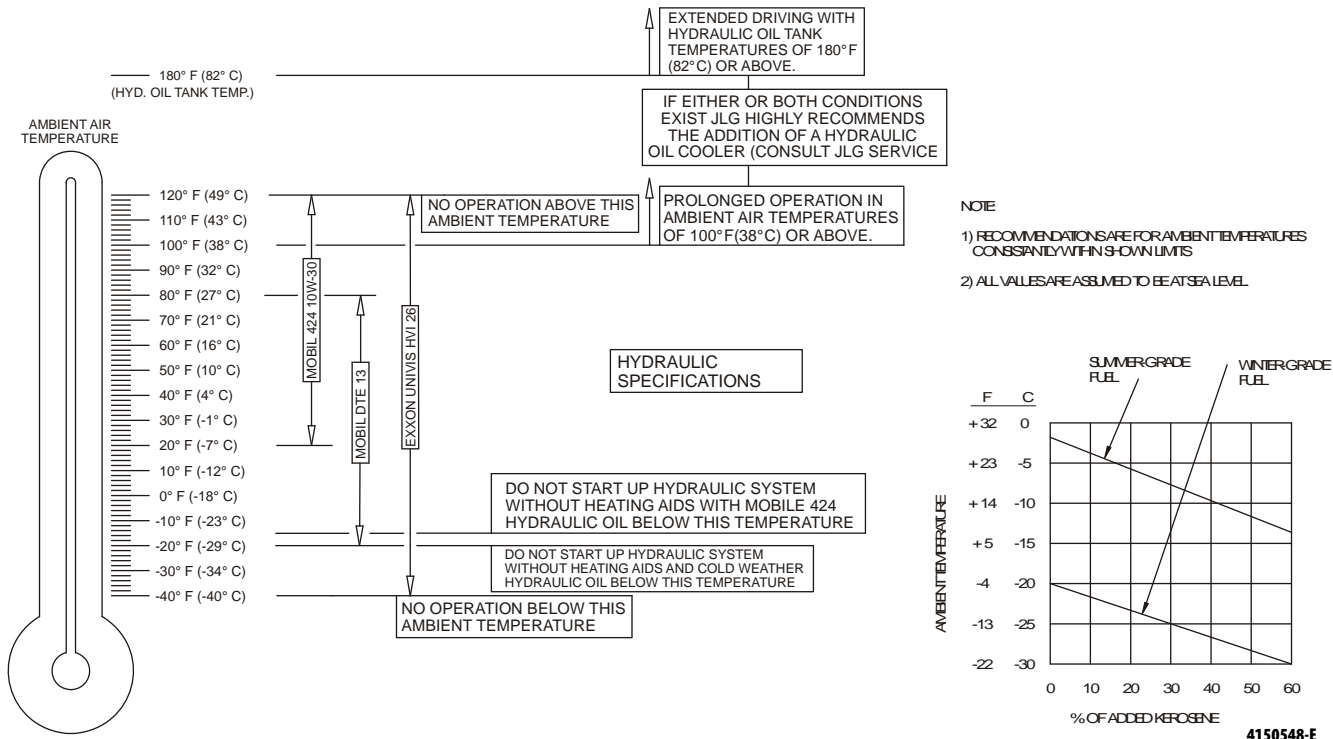
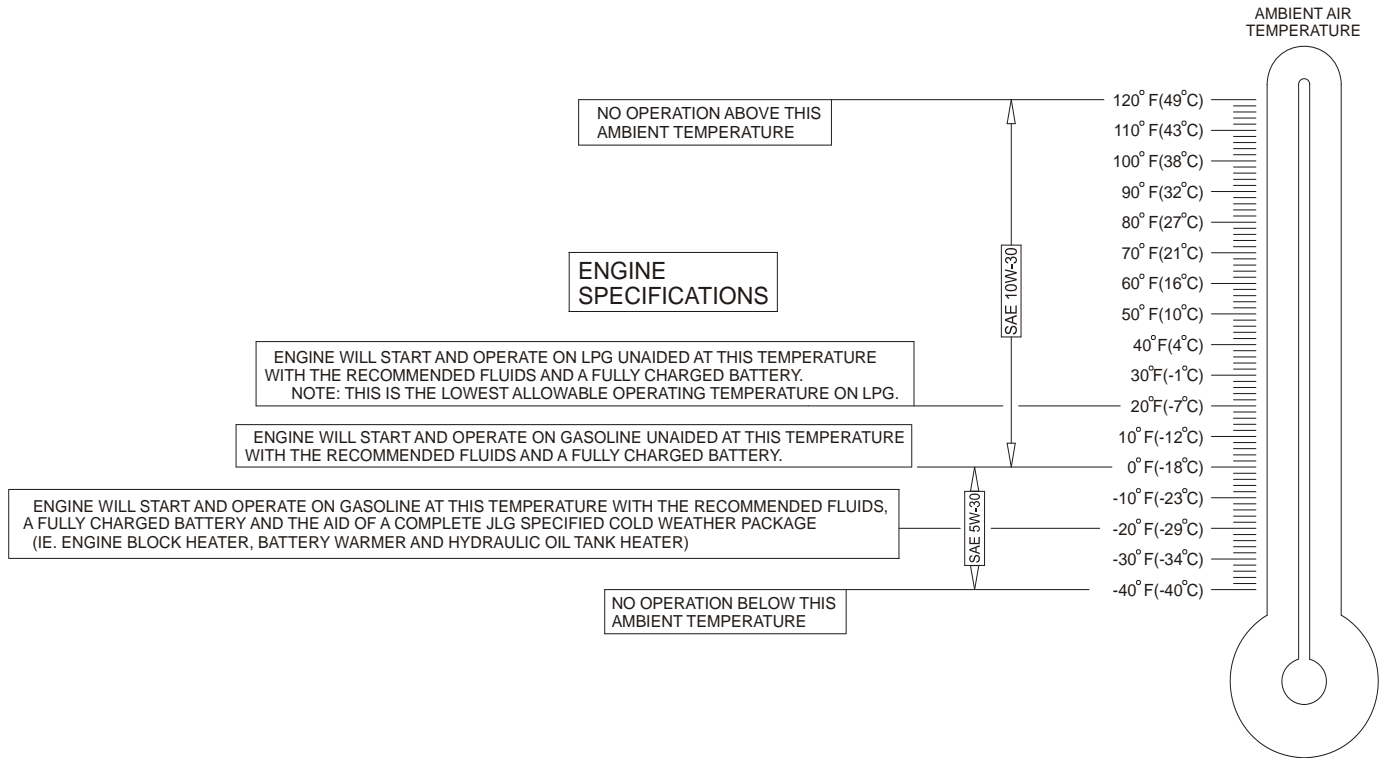

Figure 6-3. Engine Operating Temperature Specifications - Deutz - Sheet 2 of 2



## SECTION 6 - GENERAL SPECIFICATIONS & OPERATOR MAINTENANCE



**Figure 6-4. Engine Operating Temperature Specifications - GM - Sheet 1 of 2**

## SECTION 6 - GENERAL SPECIFICATIONS & OPERATOR MAINTENANCE

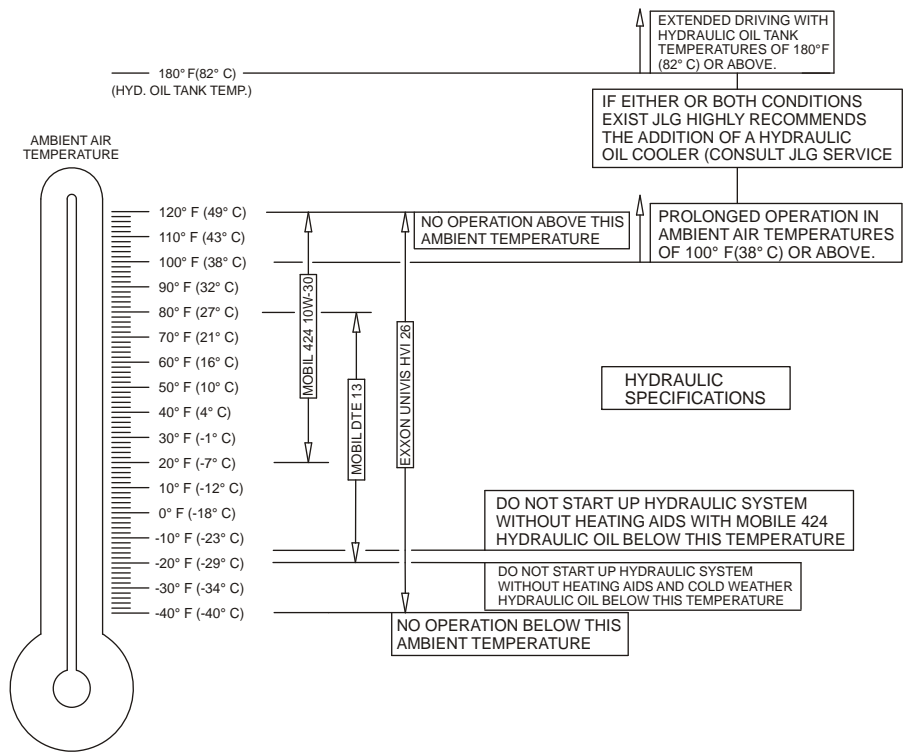

NOTE:

- 1) RECOMMENDATIONS ARE FOR AMBIENT TEMPERATURES CONSISTENTLY WITHIN SHOWN LIMITS
- 2) ALL VALUES ARE ASSUMED TO BE AT SEA LEVEL.

Figure 6-5. Engine Operating Temperature Specifications - GM - Sheet 2 of 2

4150548-E

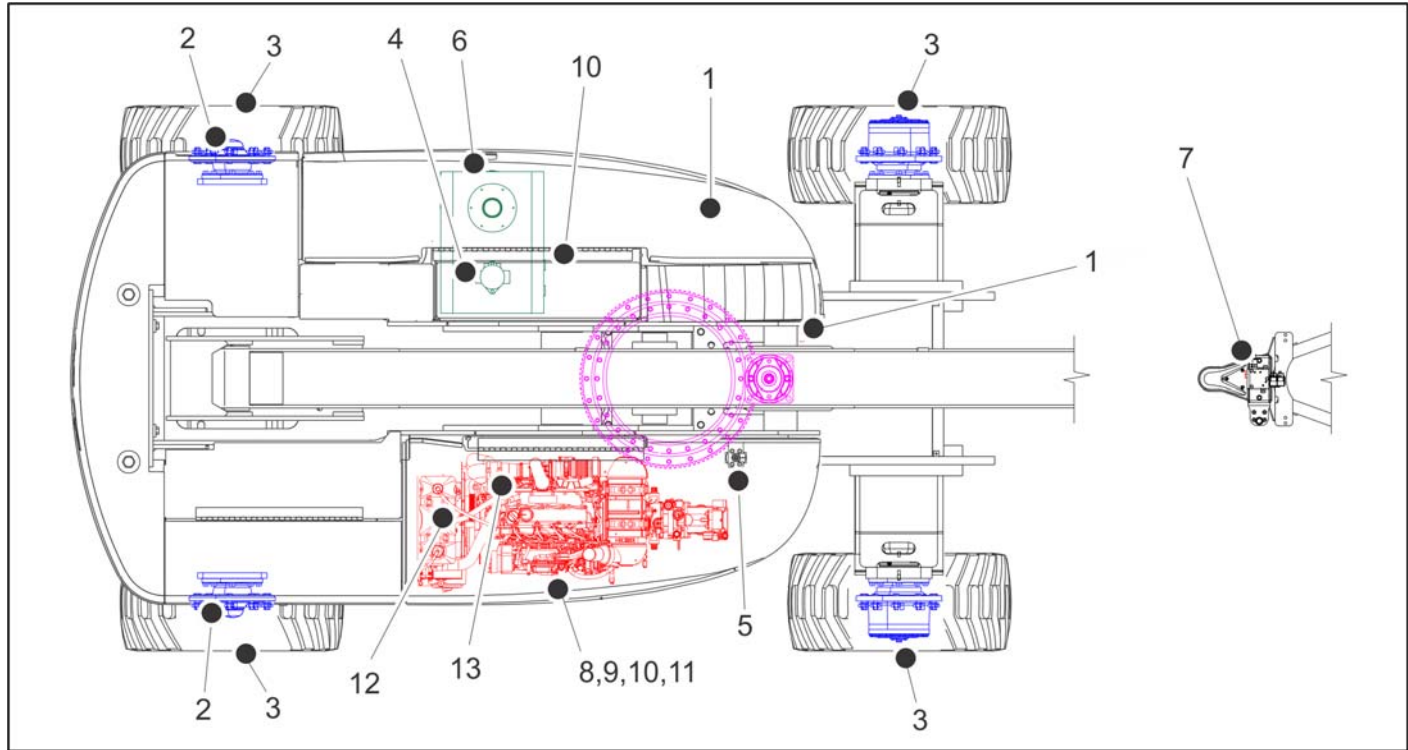

**Figure 6-6. Maintenance and Lubrication Diagram**

## SECTION 6 - GENERAL SPECIFICATIONS & OPERATOR MAINTENANCE

### 6.4 MAINTENANCE AND LUBRICATION

**NOTE:** The following numbers correspond to those in Figure 6-6., Maintenance and Lubrication Diagram.

**Table 6-16. Lubrication Specifications**

KEY	SPECIFICATIONS
MPG	Multipurpose Grease having a minimum dripping point of 350° F (177° C). Excellent water resistance and adhesive qualities, and being of extreme pressure type. (Timken OK 40 pounds minimum.)
EPGL	Extreme Pressure Gear Lube (oil) meeting API service classification GL-5 or MIL-Spec MIL-L-2105
HO	Hydraulic Oil. API service classification GL-3, e.g. Mobilfluid 424.
EO	Engine (crankcase) Oil. Gas - API SF, SH, SG class, MIL-L-2104. Diesel - API CC/CD class, MIL-L-2104B/MIL-L-2104C.

### **NOTICE**

**LUBRICATION INTERVALS ARE BASED ON MACHINE OPERATION UNDER NORMAL CONDITIONS. FOR MACHINES USED IN MULTI-SHIFT OPERATIONS AND/OR EXPOSED TO HOSTILE ENVIRONMENTS OR CONDITIONS, LUBRICATION FREQUENCIES MUST BE INCREASED ACCORDINGLY.**

**NOTE:** It is recommended as a good practice to replace all filters at the same time.

#### 1. Swing Bearing - Internal Ball Bearing

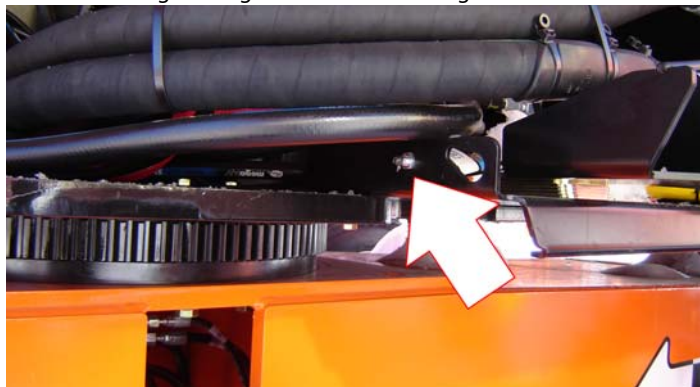

Lube Point(s) - 1 Grease Fittings  
Capacity - A/R  
Lube - MPG  
Interval - Every 3 months or 150 hrs of operation  
Comments - Remote Access

**2. Wheel Bearings**

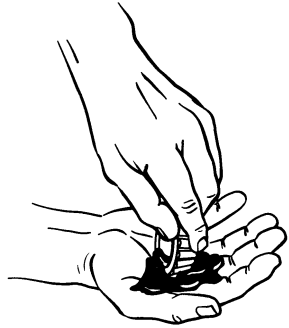

Lube Point(s) - Repack  
Capacity - A/R  
Lube - MPG  
Interval - Every 2 years or 1200 hours of operation

**3. Wheel Drive Hub**

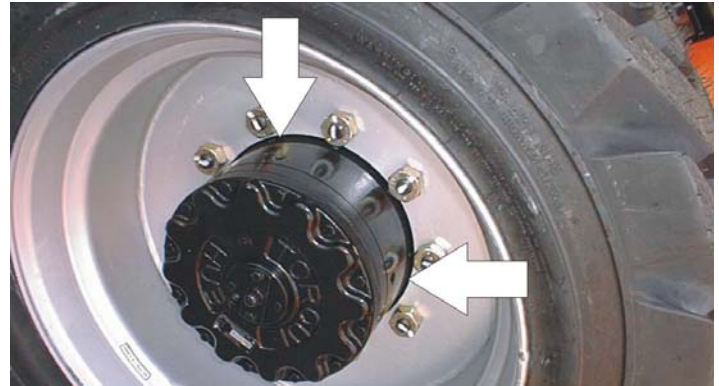

Lube Point(s) - Level/Fill Plug  
Capacity - 17 oz. (0.5 L) - 1/2 Full  
Lube - EPGL  
Interval - Check level every 3 months or 150 hrs of operation;  
change every 2 years or 1200 hours of operation  
Comments - Place Fill port at 12 o'clock position and Check  
port at 3 o'clock position. Pour lubricant into fill port until it  
just starts to flow out of check port.

## SECTION 6 - GENERAL SPECIFICATIONS & OPERATOR MAINTENANCE

---

### 4. Hydraulic Return Filter



Interval - Change after first 50 hrs. and every 6 months or 300 hrs. thereafter or as indicated by Condition Indicator.

### 5. Hydraulic Charge Filter



Interval - Change after first 50 hrs. and every 6 months or 300 hrs. thereafter or as indicated by Condition Indicator (if equipped).

## SECTION 6 - GENERAL SPECIFICATIONS & OPERATOR MAINTENANCE

### 6. Hydraulic Tank



Lube Point(s) - Fill Cap

Capacity - 116 liters Tank 124 liters System

Lube - HO

Interval - Check Level daily; Change every 2 years or 1200 hours of operation.

### 7. Platform Filter

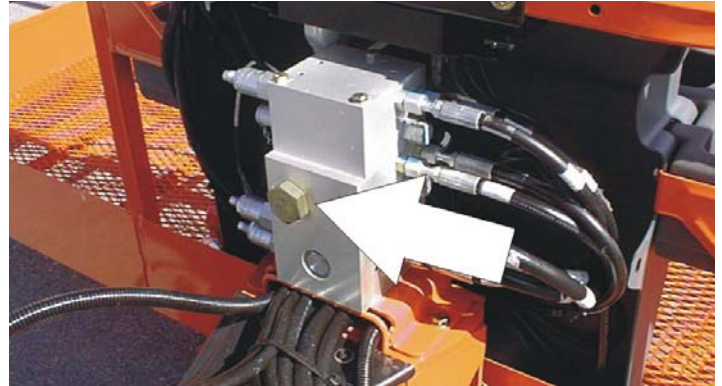

Interval - Change as necessary

## SECTION 6 - GENERAL SPECIFICATIONS & OPERATOR MAINTENANCE

### 8. Oil Change w/Filter - Deutz

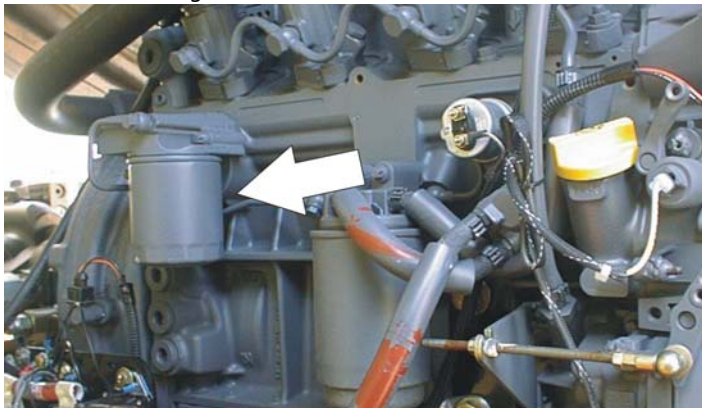

Lube Point(s) - Fill Cap/Spin-on Element  
Capacity - 11 Quarts(10.5 L) Crankcase;  
Lube - EO  
Interval - Every Year or 1200 hours of operation  
Comments - Check level daily/Change in accordance with engine manual.

### B. Oil Change w/Filter - Deutz TD2.9



Lube Point(s) - Fill Cap/Spin-on Element  
Capacity - 9.6 Quarts (9.0 L)  
Lube - EO  
Interval - Every Year or 600 hours of operation  
Comments - Check level daily/Change in accordance with engine manual.



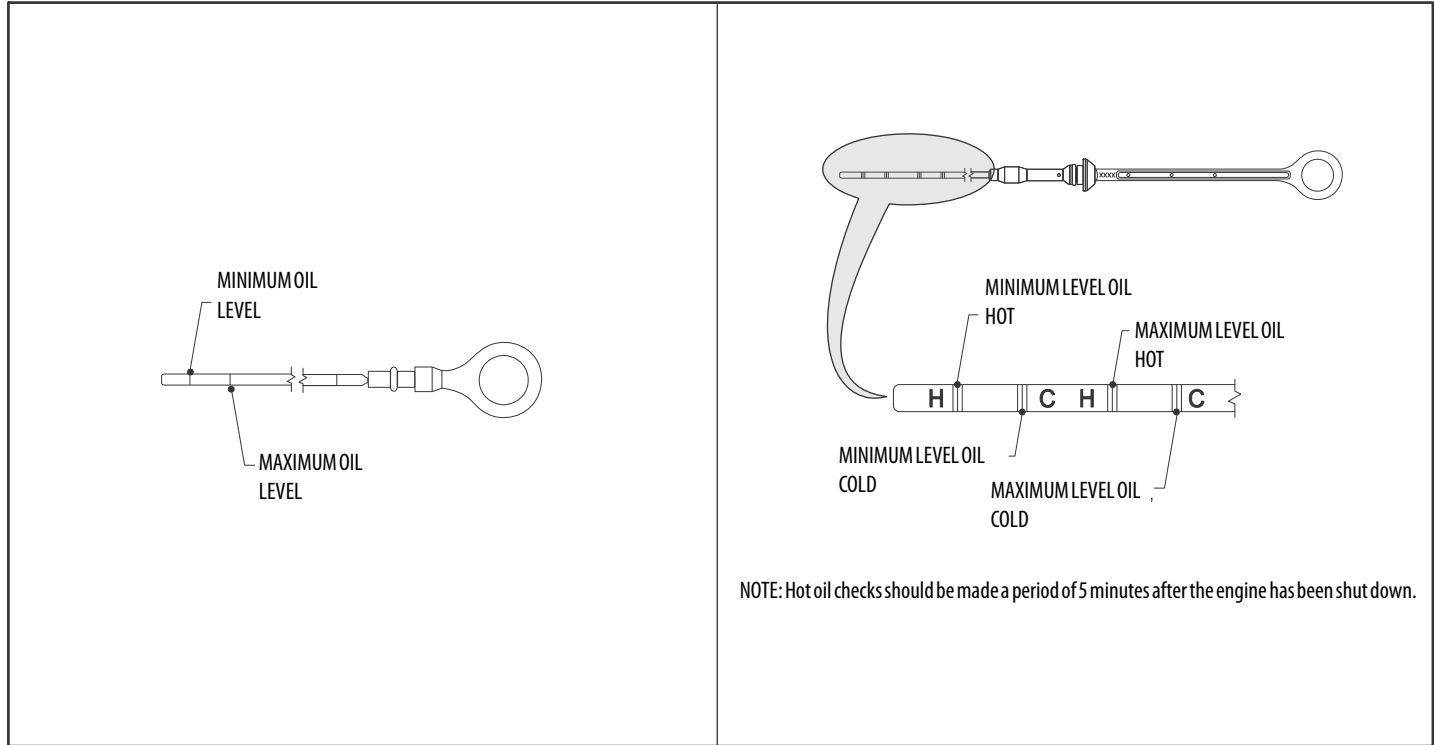

Figure 6-7. Deutz 2011 Engine Dipstick

## SECTION 6 - GENERAL SPECIFICATIONS & OPERATOR MAINTENANCE

### 9. Oil Change w/Filter - GM



Lube Point(s) - Fill Cap/Spin-on Element  
Capacity - 4.5 qt. (4.25 L) w/filter  
Lube - EO  
Interval - 3 Months or 150 hours of operation  
Comments - Check level daily/Change in accordance with engine manual.

### 10. Fuel Filter - Deutz D2011

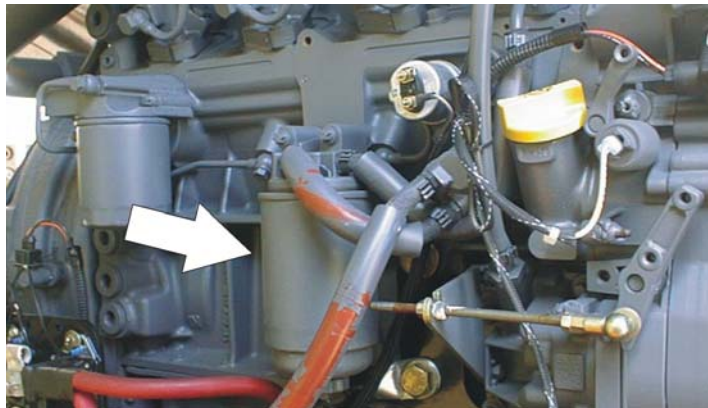

Lube Point(s) - Replaceable Element  
Interval - Every Year or 600 hours of operation

## SECTION 6 - GENERAL SPECIFICATIONS & OPERATOR MAINTENANCE

B. Fuel Filter - Deutz TD2.9 (On Hydraulic Tank)



Lube Point(s) - Replaceable Element  
Interval - Change in accordance with engine manual

C. Fuel Filter - Deutz TD2.9 (On Engine)



Lube Point(s) - Replaceable Element  
Interval - Change in accordance with engine manual

### 11. Fuel Filter (Gasoline) - GM

Lube Point(s) - Replaceable Element  
Interval - Every 6 months or 300 hours of operation

## SECTION 6 - GENERAL SPECIFICATIONS & OPERATOR MAINTENANCE

### 12. Air Filter

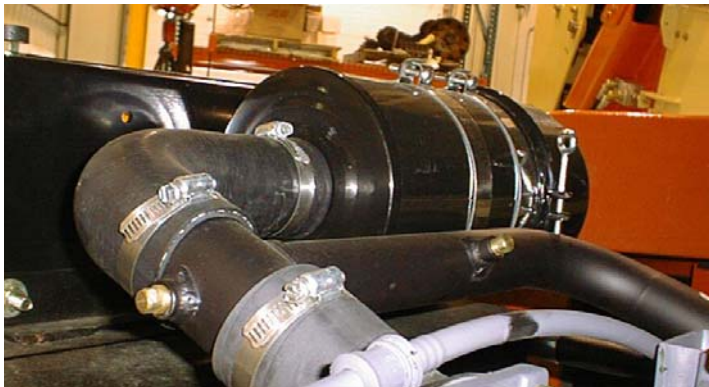

Lube Point(s) - Replaceable Element  
Interval - Every 6 months or 300 hours of operation or as indicated by the condition indicator

### B. Air Filter (Deutz TD 2.9)

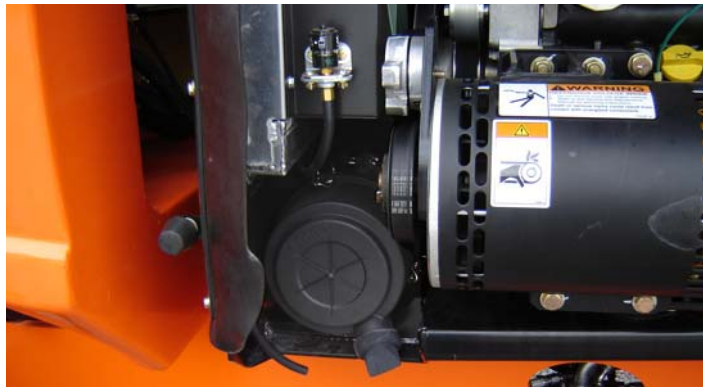

Lube Point(s) - Replaceable Element  
Interval - Every 6 months or 300 hours of operation or as indicated by the condition indicator

**13. Fuel Filter (Propane) - GM Engine**

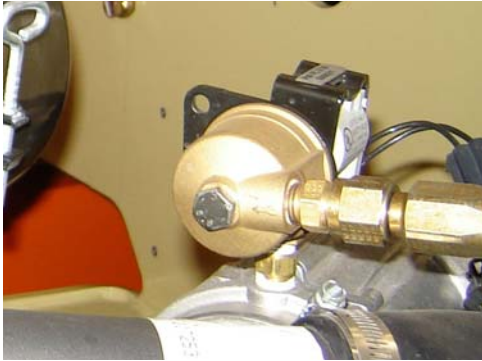

Interval - 3 Months or 150 hours of operation

Comments - Replace filter. Refer to Section 6.6, Propane Fuel Filter Replacement

**6.5 TIRES & WHEELS**

**Tire Inflation**

The air pressure for pneumatic tires must be equal to the air pressure that is stenciled on the side of the JLG product or rim decal for safe and proper operational characteristics.

**Tire Damage**

For pneumatic tires, JLG Industries, Inc. recommends that when any cut, rip, or tear is discovered that exposes sidewall or tread area cords in the tire, measures must be taken to remove the JLG product from service immediately. Arrangements must be made for replacement of the tire or tire assembly.

## **SECTION 6 - GENERAL SPECIFICATIONS & OPERATOR MAINTENANCE**

---

For polyurethane foam filled tires, JLG Industries, Inc. recommends that when any of the following are discovered, measures must be taken to remove the JLG product from service immediately and arrangements must be made for replacement of the tire or tire assembly.

- a smooth, even cut through the cord plies which exceeds 3 inches (7.5 cm) in total length
- any tears or rips (ragged edges) in the cord plies which exceeds 1 inch (2.5 cm) in any direction
- any punctures which exceed 1 inch in diameter
- any damage to the bead area cords of the tire

If a tire is damaged but is within the above noted criteria, the tire must be inspected on a daily basis to insure the damage has not propagated beyond the allowable criteria.

### **Tire Replacement**

JLG recommends a replacement tire be the same size, ply and brand as originally installed on the machine. Please refer to the JLG Parts Manual for the part number of the approved tires for a particular machine model. If not using a JLG approved replacement tire, we recommend that replacement tires have the following characteristics:

- Equal or greater ply/load rating and size of original
- Tire tread contact width equal or greater than original
- Wheel diameter, width, and offset dimensions equal to the original
- Approved for the application by the tire manufacturer (including inflation pressure and maximum tire load)

Unless specifically approved by JLG Industries Inc. do not replace a foam filled or ballast filled tire assembly with a pneumatic tire. When selecting and installing a replacement tire, ensure that all tires are inflated to the pressure recommended by JLG. Due to size variations between tire brands, both tires on the same axle should be the same.

### Wheel Replacement

The rims installed on each product model have been designed for stability requirements which consist of track width, tire pressure, and load capacity. Size changes such as rim width, center piece location, larger or smaller diameter, etc., without written factory recommendations, may result in an unsafe condition regarding stability.

### Wheel Installation

It is extremely important to apply and maintain proper wheel mounting torque.

#### **WARNING**

**WHEEL NUTS MUST BE INSTALLED AND MAINTAINED AT THE PROPER TORQUE TO PREVENT LOOSE WHEELS, BROKEN STUDS, AND POSSIBLE DANGEROUS SEPARATION OF WHEEL FROM THE AXLE. BE SURE TO USE ONLY THE NUTS MATCHED TO THE CONE ANGLE OF THE WHEEL.**

Tighten the lug nuts to the proper torque to prevent wheels from coming loose. Use a torque wrench to tighten the fasteners. If you do not have a torque wrench, tighten the fasteners with a lug wrench, then immediately have a service garage or dealer tighten the lug nuts to the proper torque. Over-tightening will result in breaking the studs or permanently deforming the mounting stud holes in the wheels. The proper procedure for attaching wheels is as follows:

1. Start all nuts by hand to prevent cross threading. DO NOT use a lubricant on threads or nuts.

## SECTION 6 - GENERAL SPECIFICATIONS & OPERATOR MAINTENANCE

2. Tighten nuts in the following sequence:

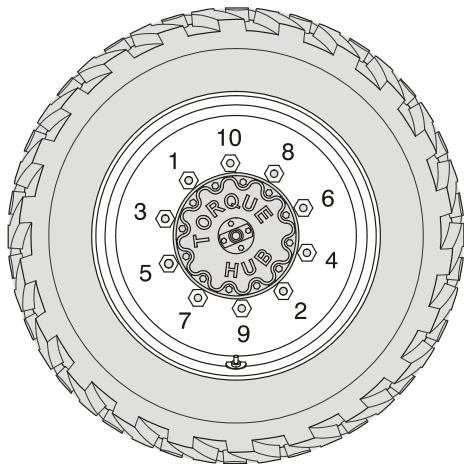

3. The tightening of the nuts should be done in stages. Following the recommended sequence, tighten nuts per wheel torque chart.

**Table 6-17. Wheel Torque Chart**

TORQUE SEQUENCE		
1st Stage	2nd Stage	3rd Stage
70 ft. lbs. (95 Nm)	170 ft. lbs. (225 Nm)	300 ft. lbs. (405 Nm)

4. Wheel nuts should be torqued after first 50 hours of operation and after each wheel removal. Check torque every 3 months or 150 hours of operation.



## **6.6 PROPANE FUEL FILTER REPLACEMENT**

### **Installation**

#### **NOTICE**

**BE SURE TO REINSTALL THE FILTER MAGNET INTO THE HOUSING BEFORE INSTALLING NEW SEAL**

### **Removal**

1. Relieve the propane fuel system pressure. Refer to Propane Fuel System Pressure Relief.
2. Disconnect the negative battery cable.
3. Slowly loosen the Filter housing and remove it.
4. Pull the filter housing from the Electric lock off assembly.
5. Remove the filter from the housing.
6. Locate Filter magnet and remove it.
7. Remove and discard the housing seal.
8. If equipped, remove and discard the retaining bolt seal.
9. Remove and discard mounting plate to lock off O-ring seal.

1. Install the mounting plate to lock off O-ring seal.
2. If equipped, install the retaining bolt seal.
3. Install the housing seal.
4. Drop the magnet into the bottom of the filter housing.
5. Install the filter into the housing.
6. If equipped, install the retaining bolt into the filter housing.
7. Install the filter up to the bottom of the electric lock off.
8. Tighten the filter bowl retainer to 106 in lbs (12 Nm).
9. Open manual shut-off valve. Start the vehicle and leak check the propane fuel system at each serviced fitting. Refer to Propane Fuel System Leak Test.

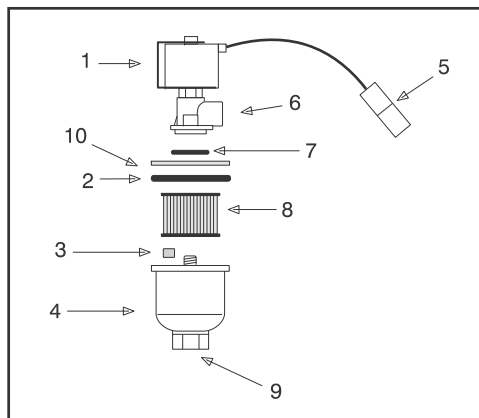

- |                               |                |
|-------------------------------|----------------|
| 1. Electric Lock Off Solenoid | 6. Fuel Outlet |
| 2. Housing Seal               | 7. O-ring      |
| 3. Filter Magnet              | 8. Filter      |
| 4. Filter Housing             | 9. Fuel Inlet  |
| 5. Electrical Connector       | 10. Ring       |

**Figure 6-8. Filter Lock Assembly**

## 6.7 PROPANE FUEL SYSTEM PRESSURE RELIEF

### **⚠ CAUTION**

**THE PROPANE FUEL SYSTEM OPERATES AT PRESSURES UP TO 312 PSI (21.5 BAR). TO MINIMIZE THE RISK OF FIRE AND PERSONAL INJURY, RELIEVE THE PROPANE FUEL SYSTEM PRESSURE (WHERE APPLICABLE) BEFORE SERVICING THE PROPANE FUEL SYSTEM COMPONENTS.**

To relieve propane fuel system pressure:

1. Close the manual shut-off valve on the propane fuel tank.
2. Start and run the vehicle until the engine stalls.
3. Turn the ignition switch OFF.

### **⚠ CAUTION**

**RESIDUAL VAPOR PRESSURE WILL BE PRESENT IN THE FUEL SYSTEM. ENSURE THE WORK AREA IS WELL VENTILATED BEFORE DISCONNECTING ANY FUEL LINE.**

## **6.8 SUPPLEMENTAL INFORMATION**

The following information is provided in accordance with the requirements of the European Machinery Directive 2006/42/EC and is only applicable to CE machines.

For electric powered machines, the equivalent continuous A-Weighted sound pressure level at the work platform is less than 70dB(A)

For combustion engine powered machines, guaranteed Sound Power Level (LWA) per European Directive 2000/14/EC (Noise Emission in the Environment by Equipment for Use Outdoors) based on test methods in accordance with Annex III, Part B, Method 1 and 0 of the directive, is 104 dB.

The vibration total value to which the hand-arm system is subjected does not exceed 2,5 m/s<sup>2</sup>. The highest root mean square value of weighted acceleration to which the whole body is subjected does not exceed 0,5 m/s<sup>2</sup>.









An Oshkosh Corporation Company

# TRANSFER OF OWNERSHIP

## To Product Owner:

If you now own but ARE NOT the original purchaser of the product covered by this manual, we would like to know who you are. For the purpose of receiving safety-related bulletins, it is very important to keep JLG Industries, Inc. updated with the current ownership of all JLG products. JLG maintains owner information for each JLG product and uses this information in cases where owner notification is necessary.

Please use this form to provide JLG with updated information with regard to the current ownership of JLG products. Please return completed form to the JLG Product Safety & Reliability Department via facsimile or mail to address as specified below.

Thank You,  
Product Safety & Reliability Department  
*JLG Industries, Inc.*  
13224 Fountainhead Plaza  
Hagerstown, MD 21742  
USA  
Telephone: +1-717-485-6591  
Fax: +1-301-745-3713

**NOTE:** Leased or rented units should not be included on this form.

Mfg. Model: \_\_\_\_\_

Serial Number: \_\_\_\_\_

Previous Owner: \_\_\_\_\_

Address: \_\_\_\_\_

Country: \_\_\_\_\_ Telephone: (\_\_\_\_) \_\_\_\_\_

Date of Transfer: \_\_\_\_\_

Current Owner: \_\_\_\_\_

Address: \_\_\_\_\_

Country: \_\_\_\_\_ Telephone: (\_\_\_\_) \_\_\_\_\_

**Who in your organization should we notify?**

Name: \_\_\_\_\_

Title: \_\_\_\_\_







## **WARNING:**



**The engine exhaust from this product contains chemicals known to the State of California to cause cancer, birth defects, or other reproductive harm.**

1702961

## **PROPOSITION 65 WARNING**

- **Battery posts, terminals and related accessories contain lead and lead compounds, chemicals known to the State of California to cause cancer and reproductive harm.**
- **Batteries also contain other chemicals known to the State of California to cause cancer.**
- **Wash hands after handling.**



An Oshkosh Corporation Company

**Corporate Office**  
**JLG Industries, Inc.**  
**1 JLG Drive**  
**McConnellsburg PA. 17233-9533**  
**USA**

**(717) 485-5161**

**(717) 485-6417**



3121630

## **JLG Worldwide Locations**

### **JLG Industries (Australia)**

P.O. Box 5119  
11 Bolwarra Road  
Port Macquarie  
N.S.W. 2444  
Australia

+61 2 65 811111

+61 2 65813058

### **JLG Latino Americana Ltda.**

Rua Eng. Carlos Stevenson,  
80-Suite 71  
13092-310 Campinas-SP  
Brazil

+55 19 3295 0407

+55 19 3295 1025

### **JLG Industries (UK) Ltd**

Bentley House  
Bentley Avenue  
Middleton

Greater Manchester  
M24 2GP - England

+44 (0)161 654 1000

+44 (0)161 654 1001

### **JLG France SAS**

Z.I. de Baulieu  
47400 Fauillet  
France

+33 (0)5 53 88 31 70

+33 (0)5 53 88 31 79

### **JLG Deutschland GmbH**

Max-Planck-Str. 21  
D - 27721 Ritterhude - Ihlpohl  
Germany

+49 (0)421 69 350 20

+49 (0)421 69 350 45

### **JLG Equipment Services Ltd.**

Rm 1107 Landmark North  
39 Lung Sum Avenue  
Sheung Shui N. T.  
Hong Kong

(852) 2639 5783

(852) 2639 5797

### **JLG Industries (Italia) s.r.l.**

Via Po. 22  
20010 Pregnana Milanese - MI  
Italy

+39 029 359 5210

+39 029 359 5845

### **Oshkosh-JLG Singapore Technology**

Equipment Pte Ltd  
29 Tuas Ave 4,  
Jurong Industrial Estate  
Singapore, 639379

+65-6591 9030

+65-6591 9031

Plataformas Elevadoras  
JLG Iberica, S.L.  
Trapadella, 2  
P.I. Castellbisbal Sur  
08755 Castellbisbal, Barcelona  
Spain

+34 93 772 4700

+34 93 771 1762

JLG Sverige AB  
Enkopingsvagen 150  
Box 704  
SE - 176 27 Jarfalla  
Sweden

+46 (0)850 659 500

+46 (0)850 659 534